

THE NEW SIMPLE INVERTER
FVR-Micro

SIMPLE & STRONG
FVR-Micro





SIMPLE & STRONG + General purpose



Noodle-making machine, Mixer



Conveyor transport

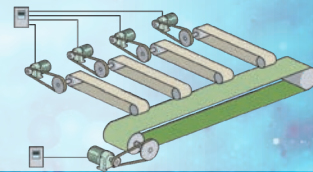

Fans, pumps

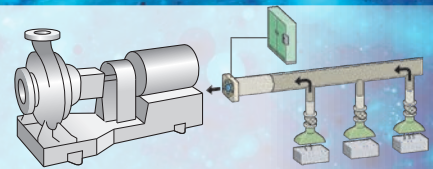

Woodworking machinery

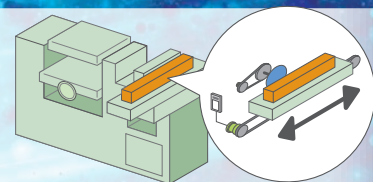

WARNING

- RISK OF INJURY OR ELECTRIC SHOCK
- Refer to the instruction manual before installation and operation
- Do not remove any cover while applying power and at least 5min after disconnecting power
- Securely ground (earth) the equipment
- High touch current

AVERTISSEMENT

- RISQUE DE BLESSURE OU DE CHOC ELECTRIQUE
- Ne retirez pas la couverture lorsque vous mettez sous tension
- De couverture peut être retiré au moins 5 minutes après la mise hors tension et quand le réseau (ACTF) s'éteint
- Plus d'un circuit électrique actif
- Reportez-vous au manuel d'instruction

警告

- 有可能引起受傷、觸電
- 安裝運行之前請務必閱讀操作說明書并遵照其指示
- 通電時及切斷電源5分鐘之內請勿打開防護面板
- 禁止觸摸機殼

Only type B of RCD is allowed.
See manual for details.

The New Simple Inverter

- Simple
- Small
- Smart

- Simple design
- Compact & Space-saving
- Once installed, enjoy easier operation



General-purpose

Playing an active role in a variety of situations



The ideal functions to serve a multiplicity of needs for small-capacity inverters

Adoption of control system to minimize motor loss

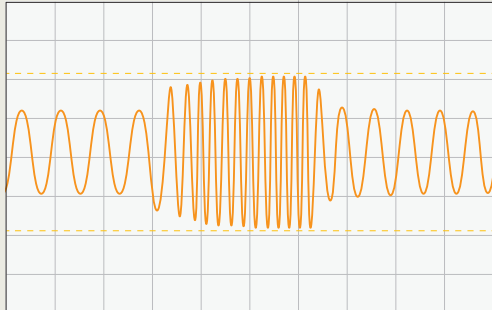

Current waveform in sudden acceleration/deceleration at 0.5Hz

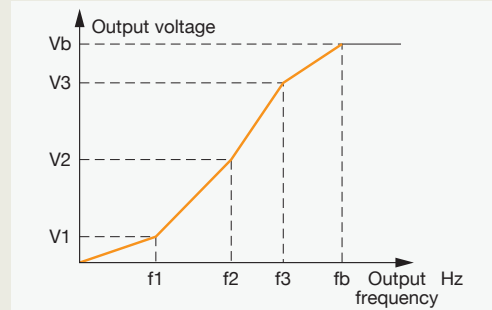

Three points can be set for a non-linear V/f pattern

Equipped with RS-485 as standard

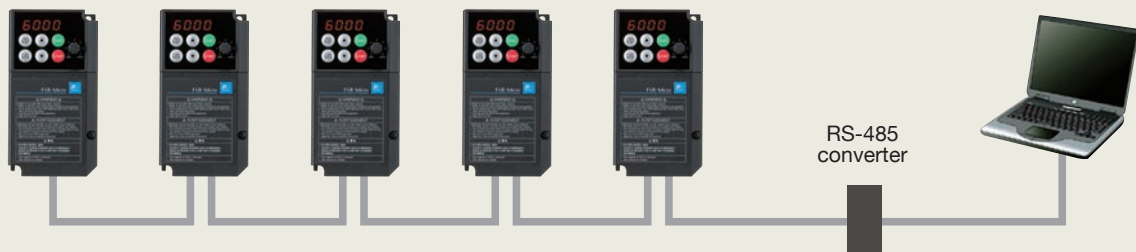

Multi-drop connection possible at terminals
Compatible with Modbus communication

Equipped with PID control function

PID control is used to eliminate disparities in actual measurement values and target values for such applications as those involving instrument control employed for fans and pumps, facilitating the control of temperature, flow rate, and pressure with proportional action (P), integral action (I), and derivative action (D).

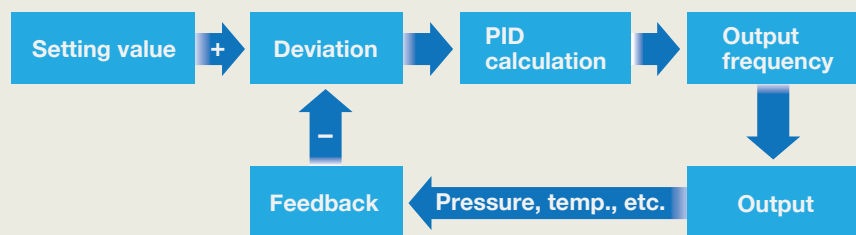

Diverse functionality

- Analog input (0 to 10V/0 to 20mA)
- Analog output (0 to 10V/0 to 20mA)
- Multi-stage frequency (16 stages)
- Jog operation
- Remote/local

Approved standard

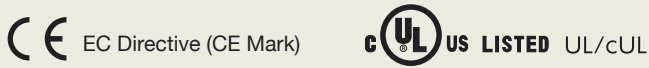

How to read the model number

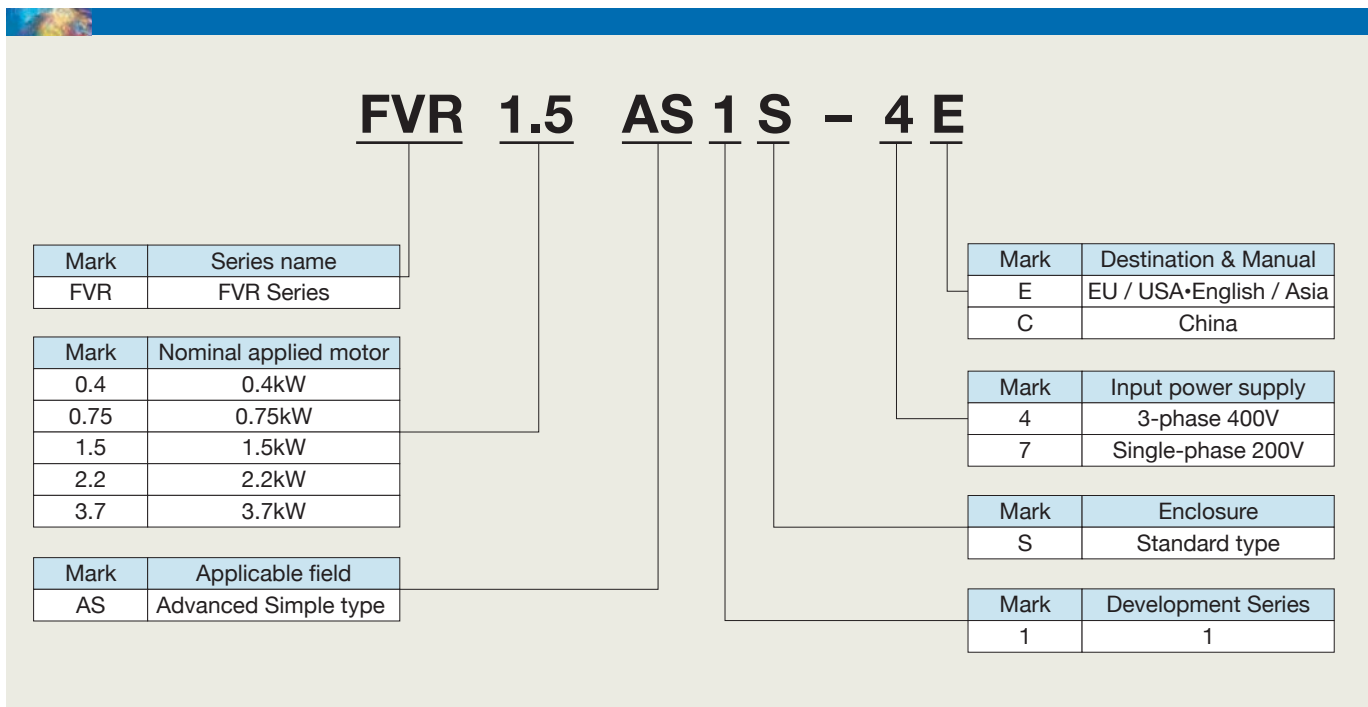

Model variation

Nominal applied motor (kW)	3-phase 400V Series	Single-phase 200V Series
Standard specifications		
0.4	FVR0.4AS1S-4E	FVR0.4AS1S-7E
0.75	FVR0.75AS1S-4E	FVR0.75AS1S-7E
1.5	FVR1.5AS1S-4E	FVR1.5AS1S-7E
2.2	FVR2.2AS1S-4E	FVR2.2AS1S-7E
3.7	FVR3.7AS1S-4E	

Technical specifications

3-phase 400V series

Item		Specification				
Type (FVR □□□ AS1S-4E)		FVR0.4AS1S-4E	FVR0.75AS1S-4E	FVR1.5AS1S-4E	FVR2.2AS1S-4E	FVR3.7AS1S-4E
Applicable motor rating [kW]		0.4	0.75	1.5	2.2	3.7
Output	Rated voltage [V]	Equal to Input voltages with the deviation of less than 5%				
	Rated current [A]*1	1.5(1.8)	2.5(2.5)	4.2(4.3)	5.5(6.3)	9.0(10.5)
	Overload capability	150% of rated output current 1 minute				
	Frequency/Fluctuation	Rated frequency : 50/60 Hz Frequency range : 0.1 to 400Hz				
Input	Voltage/Allowable	3-phase 380(-15%) to 480 V(+10%)				
	Frequency [Hz]	50Hz or 60Hz (Allowed range : 47 ~ 63Hz)				
	Input current [A]	1.7	3.1	5.9	8.2	13
Braking transistor		Built-in				
Enclosure		IP20 (IEC 60529), UL open type (UL50)				
Cooling method		Natural cooling		Fan cooling		
Mass [kg]		0.8	0.9	1.0	1.0	1.3

*1 The values in parenthesis : Ambient temperature 40°C or lower and carrier frequency 2kHz or less.

Single-phase 200V series

Item		Specification			
Type (FVR □□□ AS1S-7E)		FVR0.4AS1S-7E	FVR0.75AS1S-7E	FVR1.5AS1S-7E	FVR2.2AS1S-7E
Applicable motor rating [kW]		0.4	0.75	1.5	2.2
Output	Rated voltage [V]	Equal to Input voltages with the deviation of less than 5%			
	Rated current [A]*1	2.5(3.5)	4.2(4.2)	7.5(9.2)	10(10)
	Overload capability	150% of rated output current 1 minute			
	Frequency/Fluctuation	Rated frequency : 50/60 Hz Frequency range : 0.01 to 400Hz			
Input	Voltage/Allowable	Single-phase 200V(-10%) to 240 V(+10%)			
	Frequency [Hz]	50Hz or 60Hz (-5% to +5%)			
	Input current [A]	5.4	9.7	16.4	24
Braking transistor		Built-in			
Enclosure		IP20 (IEC 60529), UL open type (UL50)			
Cooling method		Fan cooling			
Mass [kg]		0.6	0.6	1.0	1.1

*1 The values in parenthesis : Ambient temperature 40°C or lower and carrier frequency 2kHz or less.

External Dimensions

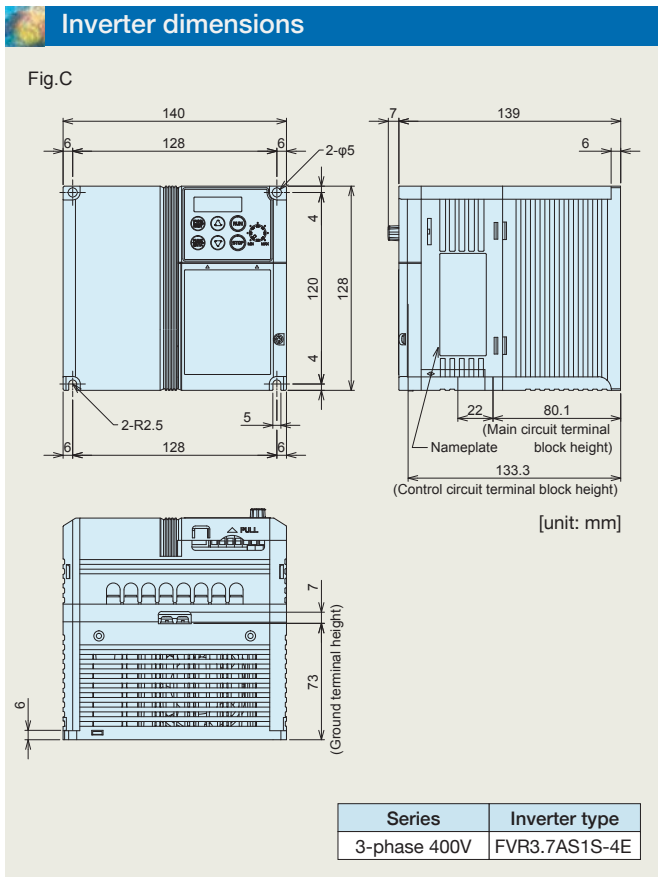
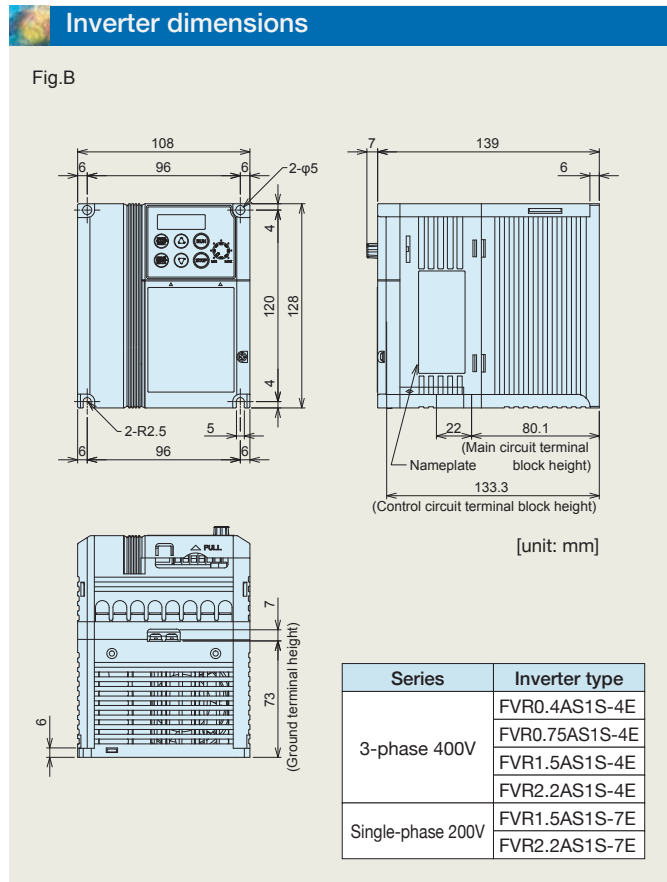
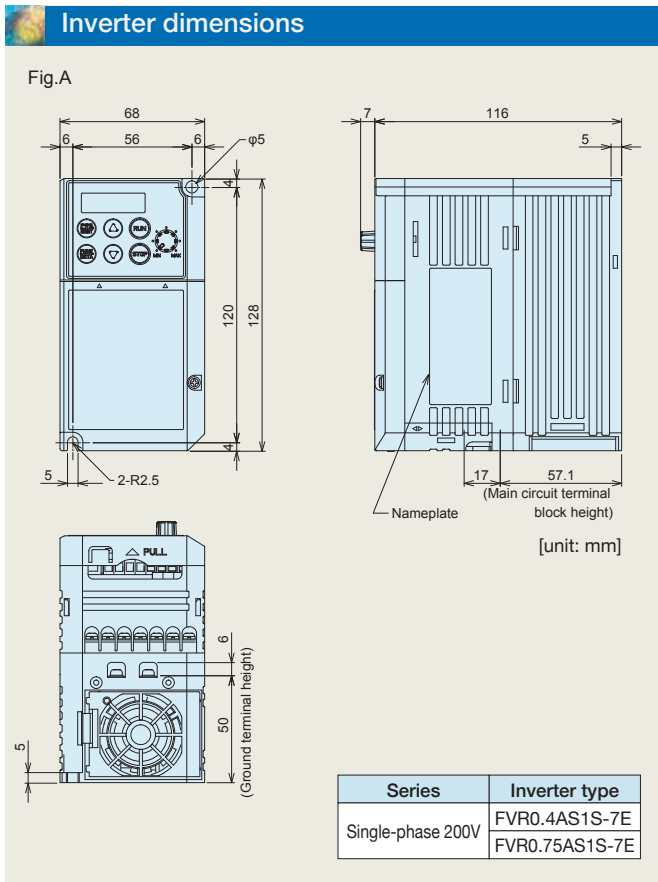



Standard wiring

Wiring diagram

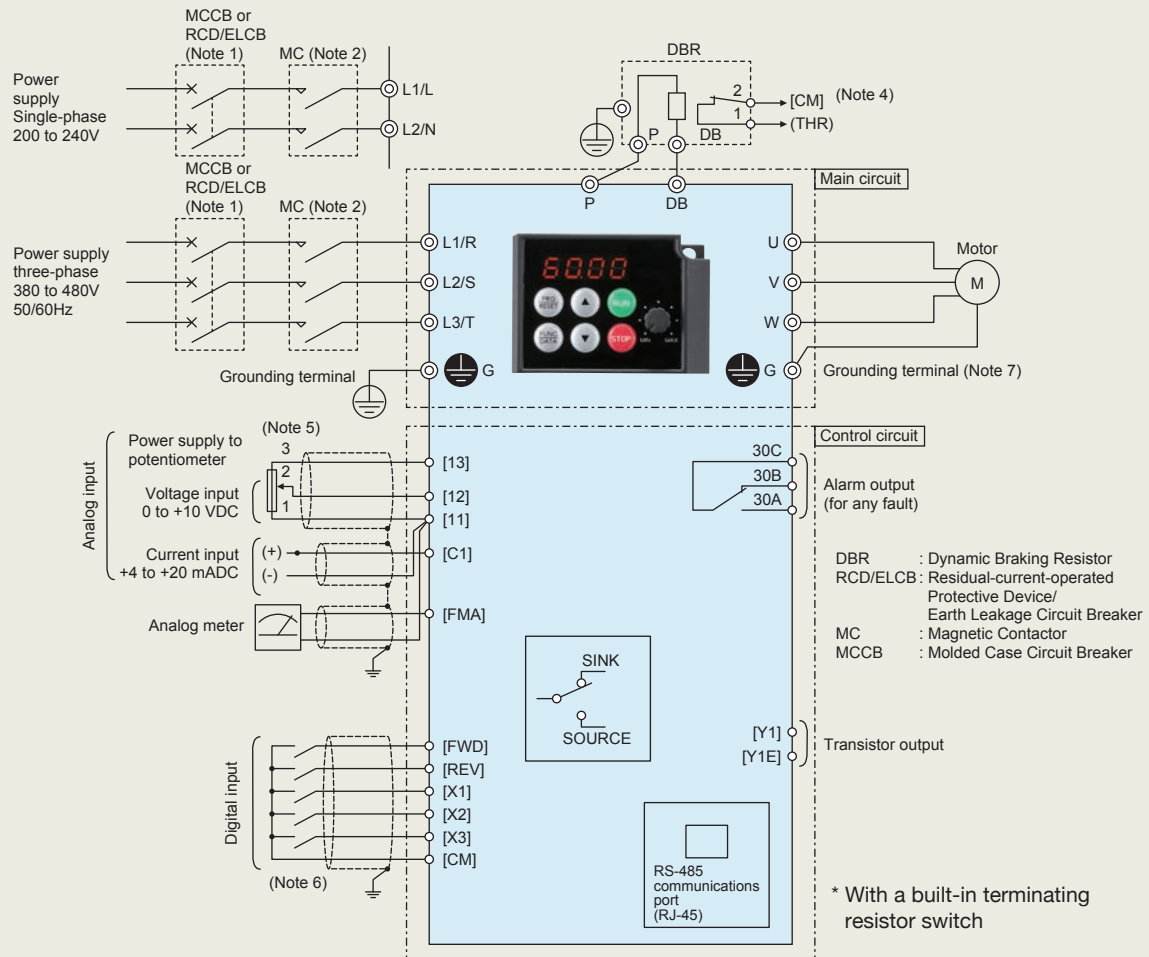

- (Note 1) Install a recommended molded case circuit breaker (MCCB) or a residual-current-operated protective device (RCD)/earth leakage circuit breaker (ELCB) (with overcurrent protection) in the primary circuit of the inverter to protect wiring. Do not use an MCCB or RCD/ELCB whose capacity exceeds the recommended rated current.
- (Note 2) A magnetic contactor (MC) should, if necessary, be mounted independent of the MCCB or ELCB to cut off the power fed to the inverter. MCs or solenoids that will be installed close to the inverter require surge absorbers to be connected in parallel to their coils.
- (Note 4) The **THR** function can be used by assigning "9" (External alarm) to any of terminals [X1] to [X3], [FWD] or [REV] (function code E01 to E03, E98, or E99).
- (Note 5) Frequency can be set by connecting a frequency setting device (external potentiometer) between terminals [11], [12], and [13] instead of inputting voltage signal (0 to +10 VDC or 0 to +5 VDC) between terminals [12] and [11].
- (Note 6) For the wiring of the control circuit, use shielded or twisted wires. When using shielded wires, connect the shields to earth. To prevent malfunction due to noise, keep the control circuit wiring away from the main circuit wiring as far as possible (recommended: 10 cm or longer), and never set them in the same wire duct. When crossing the control circuit wiring with the main circuit wiring, set them at right angles.
- (Note 7) It is recommended for noise control that 3-phase, 4-wire cable be used for the motor wiring. Connect grounding wires of the motor to the grounding terminal  G on the inverter.



NOTES

When running general-purpose motors

• Driving a 400V general-purpose motor

When driving a 400V general-purpose motor with an inverter using extremely long cables, damage to the insulation of the motor may occur. Use an output circuit filter (OFL) if necessary after checking with the motor manufacturer. Fuji's motors do not require the use of output circuit filters because of their reinforced insulation.

• Torque characteristics and temperature rise

When the inverter is used to run a general-purpose motor, the temperature of the motor becomes higher than when it is operated using a commercial power supply. In the low-speed range, the cooling effect will be weakened, so decrease the output torque of the motor. If constant torque is required in the low-speed range, use a Fuji inverter motor or a motor equipped with an externally powered ventilating fan.

• Vibration

When the motor is mounted to a machine, resonance may be caused by the natural frequencies, including that of the machine. Operation of a 2-pole motor at 60Hz or more may cause abnormal vibration.

* Study use of tier coupling or dampening rubber.

* It is also recommended to use the inverter jump frequencies control to avoid resonance points.

• Noise

When an inverter is used with a general-purpose motor, the motor noise level is higher than that with a commercial power supply. To reduce noise, raise carrier frequency of the inverter. High-speed operation at 60Hz or more can also result in more noise.

When running special motors

• Explosion-proof motors

When driving an explosion-proof motor with an inverter, use a combination of a motor and an inverter that has been approved in advance.

• Brake motors

For motors equipped with parallel-connected brakes, their braking power must be supplied from the primary circuit (commercial power supply). If the brake power is connected to the inverter power output circuit (secondary circuit) by mistake, problems may occur.

Do not use inverters for driving motors equipped with series-connected brakes.

• Geared motors

If the power transmission mechanism uses an oil-lubricated gearbox or speed changer/reducer, then continuous motor operation at low speed may cause poor lubrication. Avoid such operation.

• Single-phase motors

Single-phase motors are not suitable for inverter-driven variable speed operation. Use three-phase motors.

Environmental conditions

• Installation location

Use the inverter in a location with an ambient temperature range of -10 to 50°C.

The inverter and braking resistor surfaces become hot under certain operating conditions. Install the inverter on nonflammable material such as metal.

Ensure that the installation location meets the environmental conditions specified in "Environment" in inverter specifications.

Combination with peripheral devices

• Installing a molded case circuit breaker (MCCB)

Install a recommended molded case circuit breaker (MCCB) or an earth leakage circuit breaker (ELCB) in the primary circuit of each inverter to protect the wiring. Ensure that the circuit breaker capacity is equivalent to or lower than the recommended capacity.

• Installing a magnetic contactor (MC) in the output (secondary) circuit

If a magnetic contactor (MC) is mounted in the inverter's secondary circuit for switching the motor to commercial power or for any other purpose, ensure that both the inverter and the motor are fully stopped before you turn the MC on or off. Remove the surge killer integrated with the MC.

• Installing a magnetic contactor (MC) in the input (primary) circuit

Do not turn the magnetic contactor (MC) in the primary circuit on or off more than once an hour as an inverter fault may result. If frequent starts or stops are required during motor operation, use FWD/REV signals.

• Protecting the motor

The electronic thermal facility of the inverter can protect the general-purpose motor. The operation level and the motor type (general-purpose motor, inverter motor) should be set. For high-speed motors or water-cooled motors, set a small value for the thermal time constant to protect the motor.

If you connect the motor thermal relay to the motor with a long cable, a high-frequency current may flow into the wiring stray capacitance. This may cause the relay to trip at a current lower than the set value for the thermal relay. If this happens, lower the carrier frequency or use the output circuit filter (OFL).

• Discontinuance of power-factor correcting capacitor

Do not mount power factor correcting capacitors in the inverter (primary) circuit. Use a DC reactor to improve the inverter power factor. Do not use power factor correcting capacitors in the inverter output circuit (secondary). An overcurrent trip will occur, disabling motor operation.

• Discontinuance of surge killer

Do not mount surge killers in the inverter output (secondary) circuit.

• Reducing noise

Use of a filter and shielded wires are typical measures against noise to ensure that EMC Directives are met.

• Measures against surge currents

If an overvoltage trip occurs while the inverter is stopped or operated under a light load, it is assumed that the surge current is generated by open/close of the phase-advancing capacitor in the power system.

We recommend connecting a DC REACTOR to the inverter.

• Megger test

When checking the insulation resistance of the inverter, use a 500V megger and follow the instructions contained in the Instruction Manual.

Wiring

• Wiring distance of control circuit

When performing remote operation, use twisted shielded wire and limit the distance between the inverter and the control box to 20m.

• Wiring length between inverter and motor

If long wiring is used between the inverter and the motor, the inverter will overheat or trip as a result of overcurrent (high-frequency current flowing into the stray capacitance) in the wires connected to the phases. Ensure that the wiring is shorter than 50m. If this length must be exceeded, lower the carrier frequency or mount an output circuit filter (OFL).

When wiring is longer than 50m, and sensorless vector control or vector control with speed sensor is selected, execute off-line tuning.

• Wiring size

Select cables with a sufficient capacity by referring to the current value or recommended wire size.

• Wiring type

Do not use multicore cables that are normally used for connecting several inverters and motors.

• Grounding

Securely ground the inverter using the grounding terminal.

Selecting inverter capacity

• Driving general-purpose motor

Select an inverter according to the applicable motor ratings listed in the standard specifications table for the inverter. When high starting torque is required or quick acceleration or deceleration is required, select an inverter with a capacity one size greater than the standard.

• Driving special motors

Select an inverter that meets the following condition: Inverter rated current > Motor rated current.

Transportation and storage

When transporting or storing inverters, follow the procedures and select locations that meet the environmental conditions that agree with the inverter specifications.