

Low voltage AC drives for pumping water & compressors applications

FRENIC-AQUA



Smile to the environment



High performance enabled by the comprehensive use of Fuji technology.
Easy maintenance for the end-user. Maintains safety and protects the environment. Opens up possibilities for the new generation.

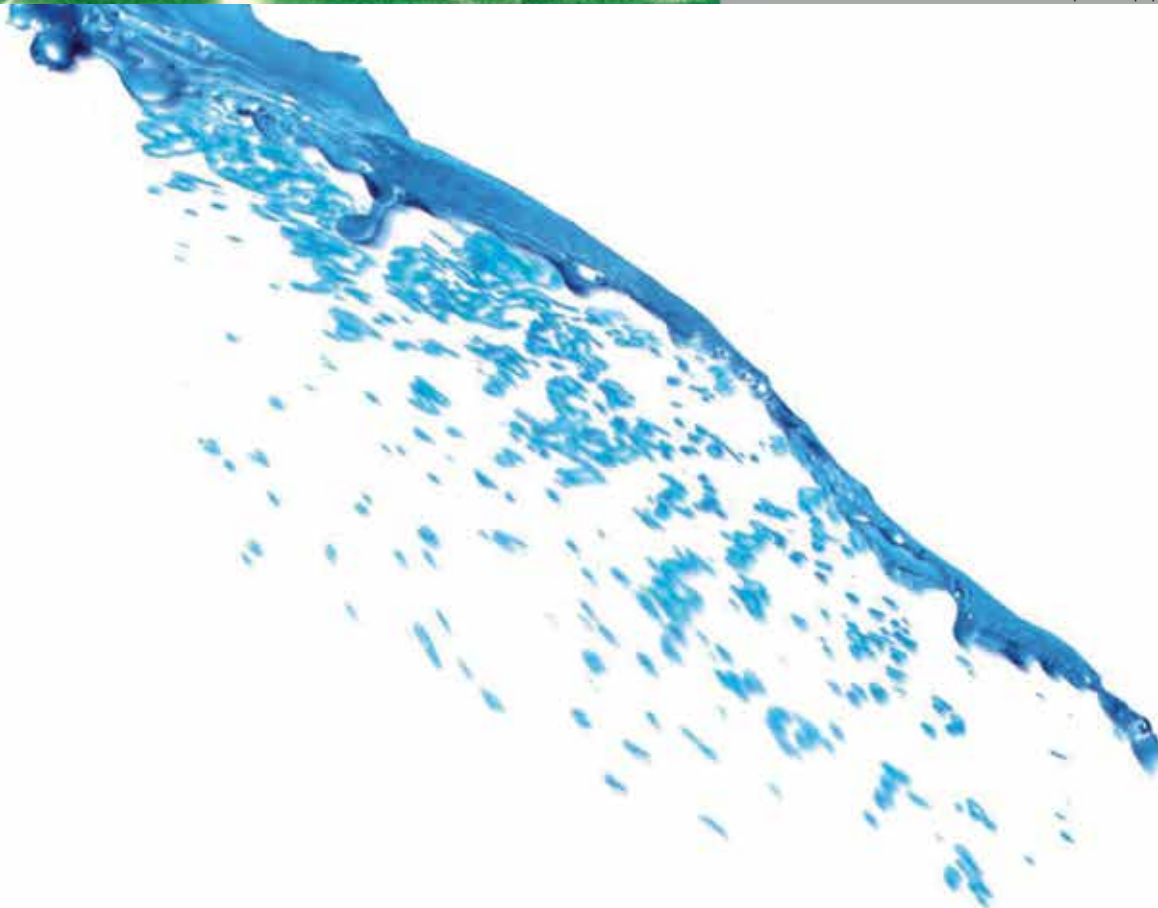



Wide variation in model capacity (0.75 - 710) kW

Model can be selected from two model types.

- **Standard type (EMC filter built-in type)**
0.75 to 710kW (Protective structure IP21 or IP55 can be selected between 0.75 and 90kW.)
- **DCR built-in + EMC filter built-in type**
0.75 to 90kW (Protective structure IP21 or IP55 can be selected between 0.75 and 90kW.)

Inverter capacity	EMC Filter	DC Reactor	Protective Structure
0.75 kW to 90 kW	Built-in	Built-in	IP21/IP55
110 kW to 710 kW	Built-in	External	IP00

Optimum control by energy saving functions

- Linearization function
- Temperature difference constant control and pressure difference constant control
- Automatic energy-saving operation

Dedicated pump control function provided as standard

- 4PID control • Cascade control • Mutual operation • Control of maximum starts per hour
- Dry pump detection • Deceleration time for check valve protection • Slow flowrate function
- End of curve detection • Boost function • Acceleration and deceleration at initial stage

Slim body

The first slim body design among the Fuji Electric inverters.
The size is the same for IP21 and IP55.

User-friendly functions

- Fire mode (forced operation) • Customized logic
- Pick-up operation function • Anti-jam
- Torque vector control • Password function
- Real time clock • User-friendly intuitive keypad



Wide usage for water & air treatment

- Water purification plant and waste water and sewage treatment plants

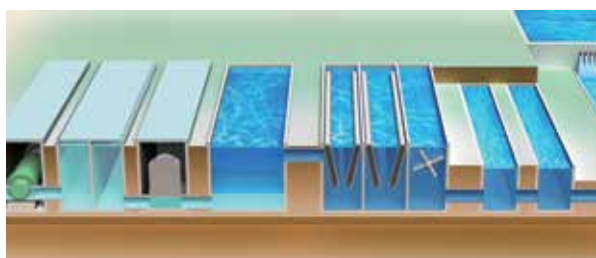

- Irrigation system



- Pump



Characteristics in pump usage	Advantages
Cascade control (Max. 8 units + 1 unit [auxiliary motor]) (Homogenization of operation hour)	Cost reduction Longer service life of the system
Built-in PID controller	Process optimization Cost cutting
Dry pump detection	Pump protection Energy saving
Mutual operation	Initial cost cutting
Condensation prevention function	No heater required

- Blower

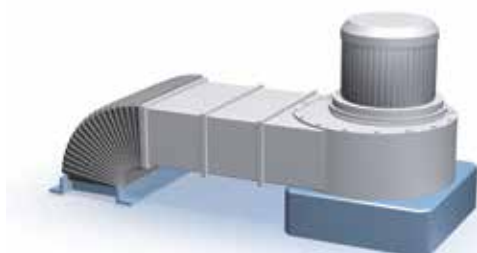

Characteristics in blower usage	Advantages
Built-in PID controller	Process optimization Cost cutting
Automatic energy-saving operation (Energy-saving operation according to load)	Energy saving
Condensation prevention function	No heater required
Pick-up operation	Blower protection

FRENIC-AQUA series is equipped with many functions that control the pumps and blowers used in water treatment facility optimally.

- Fluid-pressure device

- Oil pumping system
- Injection machine
- Hydraulic press machine
- Extruders



Optimal structure design

User-friendly keypad

- The regulator is indicated by enlarging the LCD.

- | | | |
|----------------------------|-------------------|-----------------------|
| 1. Present value (PV) | 5. Output current | 9. Power consumption |
| 2. Setting value (SV) | 6. Output voltage | 10. Cumulative energy |
| 3. Manipulating value (MV) | 7. Torque | |
| 4. Frequency | 8. Rotation speed | |



*Possible to show understandable indications through the unit conversion function.
 *Multi-language function: 19 languages + user customized language supported

- Multi-language supported: 19 languages + user customized language

Language				
English	Dutch	Turkish	Greek	Vietnamese
Spanish	Italian	Russian	Malay	Chinese
German	Czech	Swedish	Indonesian	Thai
French	Polish	Portuguese	Japanese	

Real time clock (RTC) provided as standard

- Alarm information with date and time

- Alarm information for last ten times is stored and displayed with date and time.

Easy failure analysis

- Timer function

- Possible to set up to four timers a week.
- Possible to set flag holidays (20 days a year).

Operation schedule can be set according to actual condition by using four timers

Example When operation is performed in the same schedule through a week

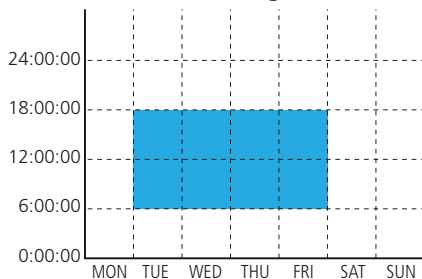

When operation schedule varies depending on the day of the week

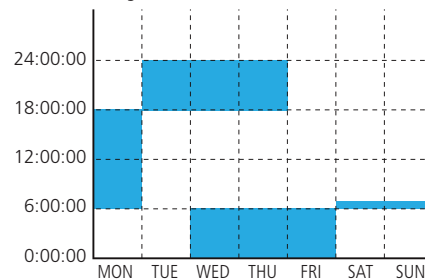

- Unit conversion function between PV and SV values

- Unit conversion allows you to easily set data.

Function	Units				
Unit conversion	No conversion	%	r/min	kW	m ³ /s
	m ³ /min	m ³ /h	L/s	L/min	L/h
	Pa	kPa	MPa	mbar	bar
	mmHg	psi	mWG	inWG	K
	°C	°F	ppm		

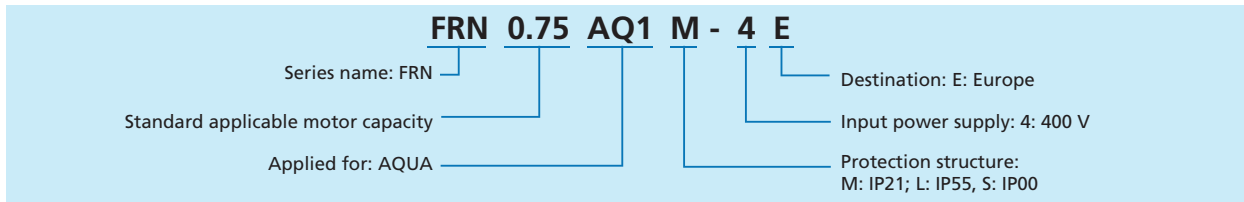

1 User-friendly, easy to see dedicated keypad

Multi-language supported, HELP function featured, unit setting with SV and PV values, data copy (three kinds), detachable and can be attached on the panel (using an optional cable)

4 Capacitor board

Outputs the life prediction signal determining capacitor capacity drop and cumulative running hours. This allows the user to grasp replacement period.

5 Cooling fan

Easy replacement just by simply removing and attaching the part. Life prolongation is possible by controlling ON and OFF.

2 Control board

USB port equipped.
Max. three types of built-in optional boards can be mounted all together.
Optional battery connection.
Various communications options.

3 Control terminal block

The detachable control terminal block is adopted. This allows the unit to be replaced easily without disconnecting cables.

6 EMC filter

Drastically reduces noise. Provided to units of all capacities. Conforming to IEC61800-3.

7 DCR

Drastically reduces harmonic noise. Conforming to IEC/EN61000-3-2 and IEC/EN61000-3-12. Provided as standard (to models up to 90kW), and can be attached externally as an option (to models from 110kW to 710kW).

8 Environmental immunity

3C3 for SO₂ and NO₂, 3C2 for all gases. IEC 60721-3-3.

9 Others

Support/analysis software by loader, RTC backup by battery (option).

Standard equipment	Optional equipment
<ul style="list-style-type: none"> • BACnet MS/TP • Modbus RT • Metasys N2 	<ul style="list-style-type: none"> • LonWorks • Ethernet • Profibus • DeviceNet • CANopen • CC-Link

Optimal function for usage in water treatment

Cascade control

1. Inverter drive motor fixed method (FIXED)

The system is configured by combining the motor driven by the inverter (M0), with motors that are commercially driven (M1 to M8) and auxiliary motor (MA). The motor driven by the inverter is always fixed as motor M0. Motors commercially driven are added one by one in control when the required discharge flow rate cannot be achieved with the motor M0 only.

Inverter drive motor fixed method (FIXED)

Max. **1 unit** (Driven by inverter) + **8 units** (Commercially driven) + **1 unit** (Auxiliary motor)

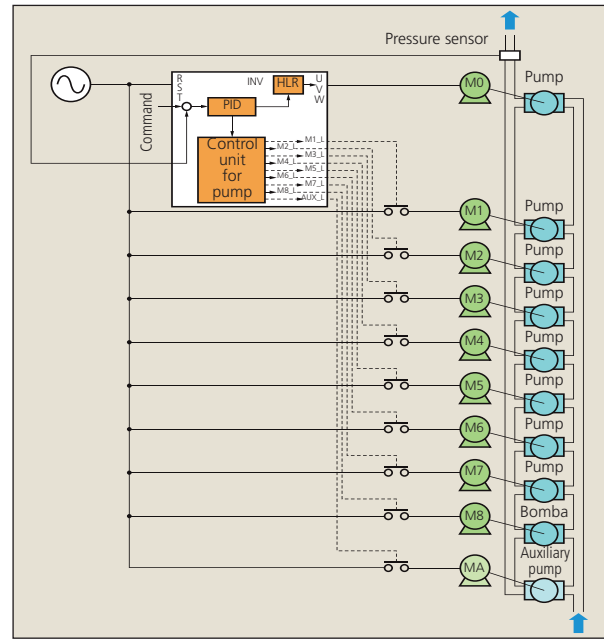

2. Inverter drive motor floating method (FLOATING)

The system for this method is configured by combining the motors that can be switched between inverter drive and commercial drive (M1 to M4) and auxiliary motor that are commercially driven (MA). The motors are driven by the inverter with variable speed control at start. When the desired discharge flow rate cannot be achieved with the first motor, operations FLOATING-1 or FLOATING-2 can be selected.

Inverter drive motor floating method (FLOATING)

Max. **4 units** + **1 unit** (Auxiliary motor)

Floating 1:

The first motor: Switched as a commercially driven motor
Second and subsequent motors: Operated by inverter drive
 The inverter-driven motor is changed by rotation as the motor is added.

Floating 2:

The first motor: Inverter drive continued
Second and subsequent motors: Commercially driven

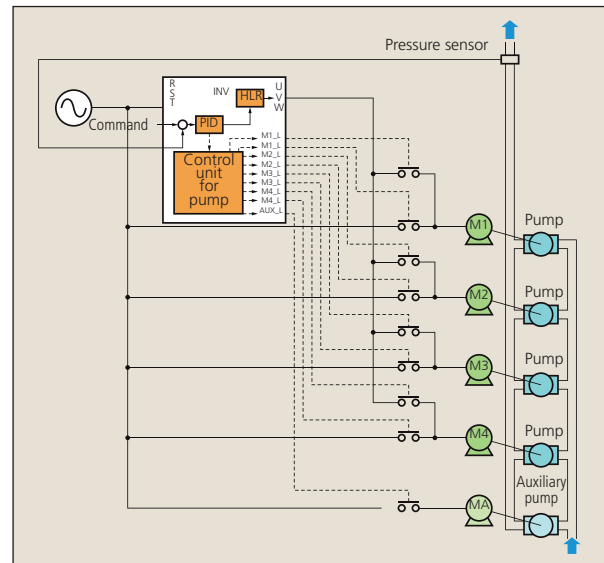

Mutual operation

The system can be configured without using a controller by connecting the inverters via communications. In this system, if a failure occurs to the master inverter, the next inverter is driven as the master inverter. Moreover, wiring can be saved with use of communications services, which eliminates the need of additional options by using the Modbus RTU communications.

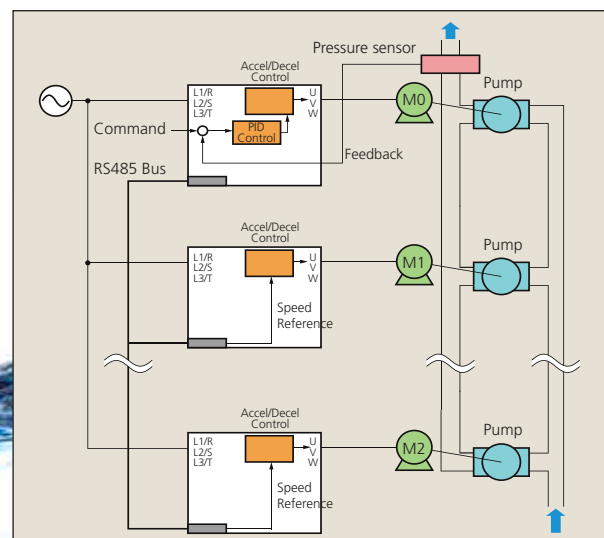

Customized logic

The customized logic interface function is provided to the inverter body. This enables forming of logic circuit and arithmetic circuit to the digital and analog input and output

signals, allowing simple relay sequence to be built while processing the signals freely. 14 steps can be used.

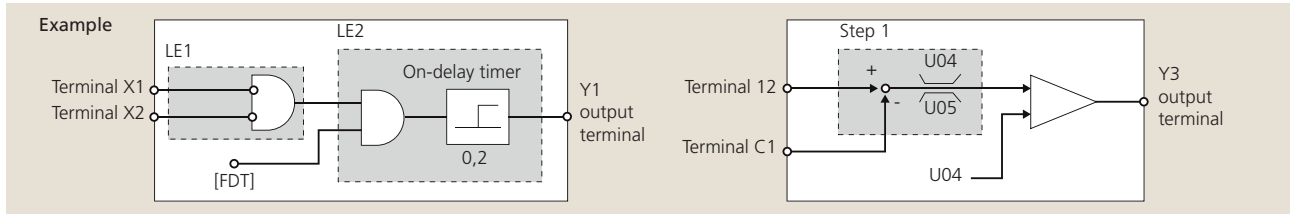

Boost function

Frequency can be output forcibly at a fixed rate in preference to PID control. By setting the operation frequency, operation time, and acceleration time as starting, optimal operation for starting the pump can be achieved.

- Pressurizing operation can be applied for a certain period of time at the time of start.

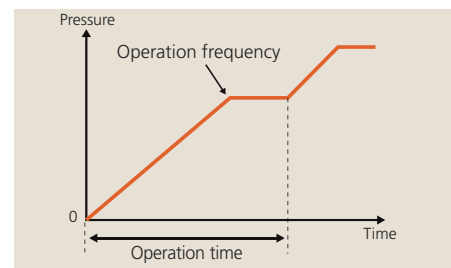

Slow flowrate function (pressurized operation available before slow flowrate)

The inverter can be stopped when the discharge rate becomes low due to increase of pump discharge pressure. Facility having a bladder tank can make the stoppage period

longer by applying pressure immediately before stoppage, which realizes energy-saving operation.

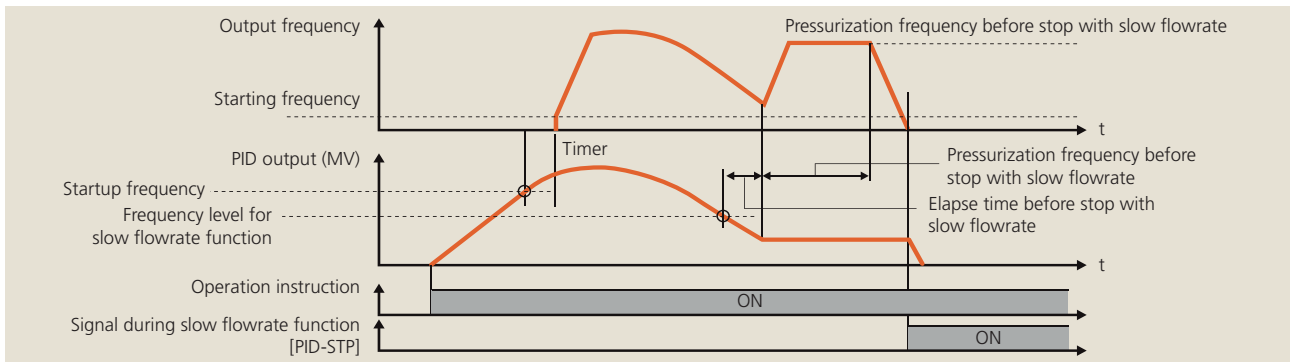

Initial acceleration/deceleration time

When a pump such as a deep well pump is operated at low speed over a long period of time, the pump may be damaged since the load current is large in the low-speed range.

It is possible to provide acceleration / deceleration time specific to the low-speed range in order to avoid prolonged operation.

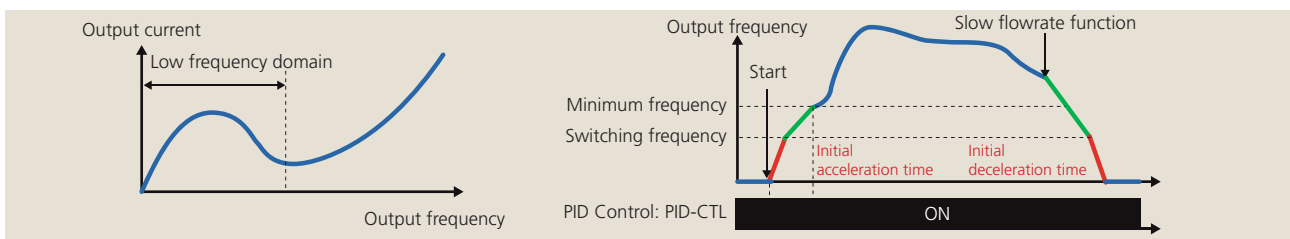

Other featured functions

- 4PID control
- Control of maximum starts per hour
- Abnormal pressure rise prevention
- End of curve detection
- Pick-up operation
- Dry pump detection
- Password
- Deceleration time for check valve protection

Standard specifications

3-phase, 400 V (0.75 to 710 kW)

Item		Specifications													
Model	FRN□□□AQ1□-4E: AQUA	0.75	1.5	2.2	4.0	5.5	7.5	11	15	18.5	22	30	37	45	55
Applicable standard motor (rated output) [kW] ^{*1}		0.75	1.5	2.2	4.0	5.5	7.5	11	15	18.5	22	30	37	45	55
Output ratings	Rated capacity [kVA] ^{*2}	1.9	3.1	4.1	6.8	10	14	18	24	29	34	45	57	69	85
	Voltage [V] ^{*2}	3-phase, 380 to 480 V (with AVR function)													
	Rated current [A]	2.5	4.1	5.5	9.0	13.5	18.5	24.5	32	39	45	60	75	91	112
	Overload current rating	110%-1min (Overload tolerated interval: compliant with IEC 61800-2)													
	Rated frequency [Hz]	50, 60 Hz													
Input power supply	Main power supply (no. of phase, voltage, frequency)	3-phase, 380 to 440 V, 50 Hz / 3-phase 390 to 480 V, 60 Hz													
	Control power supply auxiliary-input (no. of phase, voltage, frequency)	Single phase, 380 to 480 V, 50/60 Hz													
	Voltage, frequency variations	Voltage: +10 to -15% (Unbalance rate between phases is within 2%)* ⁴ Frequency : +5 to -5%													
	Rated input current [A]	1.6	3.0	4.3	7.4	10.3	13.9	20.7	27.9	34.5	41.1	55.7	69.4	83.1	102
	Required power supply capacity [kVA]	1.2	2.1	3.0	5.2	7.2	9.7	15	20	24	29	39	49	58	71
Braking	Braking torque [%] ^{*5}	20										10 to 15			
	DC braking	Braking starting frequency: 0.0 to 60.0Hz, Braking time: 0.0 to 30.0s, Braking level: 0 to 60%													
EMC filter (IEC/EN61800-3:2004)		Compliant with EMC standard: Emission: 1st Env. (Category C2) / Immunity: 1st and 2nd Env.													
DC Reactor		Built-in (IEC/EN61000-3-2, IEC/EN61000-3-12)													
Compliant with Electrical Safety Standards		UL508C, C22.2No.14, IEC/EN61800-5-1:2007													
"#" Enclosure (IEC/EN60529)		IP21/IP55													
Cooling method		Fan cooling													
Weight/Mass [kg]	IP21/IP55	10	10	10	10	10	10	18	18	18	18	23	23	50	50

Item		Specifications													
Model	FRN□□□AQ1□-4E: AQUA	75	90	110	132	160	200	220	280	315	355	400	500	630	710
Applicable standard motor (rated output) [kW] ^{*1}		75	90	110	132	160	200	220	280	315	355	400	500	630	710
Output ratings	Rated capacity [kVA] ^{*2}	114	134	160	192	231	287	316	396	445	495	563	731	891	1044
	Voltage [V] ^{*2}	3-phase, 380 to 480V (with AVR function)													
	Rated current [A]	150	176	210	253	304	377	415	520	585	650	740	960	1170	1370
	Overload current rating	110%-1min (Overload tolerated interval: compliant with IEC 61800-2)													
	Rated frequency [Hz]	50, 60 Hz													
Input power supply	Main power supply (no. of phase, voltage, frequency)	3-phase, 380 to 440 V, 50 Hz / 3-phase 390 to 480 V, 60 Hz													
	Control power supply auxiliary-input (no. of phase, voltage, frequency)	Single phase, 380 to 480V, 50/60 Hz													
	Voltage, frequency variations	Voltage: +10 to -15% (Unbalance rate between phases is within 2%)* ⁴ Frequency : +5 to -5%													
	Rated input current [A]	136	162	201	238	286	357	390	500	559	628	705	881	1115	1256
	Required power supply capacity [kVA]	95	113	140	165	199	248	271	347	388	436	489	611	773	871
Braking	Braking torque [%] ^{*5}	10 to 15													
	DC braking	Braking starting frequency: 0.0 to 60.0 Hz, Braking time: 0.0 to 30.0s, Braking level: 0 to 60%													
EMC filter (IEC/EN61800-3:2004)		same as 0.75 to 55 kW	Compliant with EMC standard: Emission: 2nd Env. (Category C3) / Immunity: 1st and 2nd Env.												
DC Reactor		IEC/EN61000-3-2, IEC/EN61000-3-12													
Compliant with Electrical Safety Standards		UL508C, C22.2No.14, IEC/EN61800-5-1:2007													
"#" Enclosure (IEC/EN60529)		IP21/IP55		IP00											
Cooling method		Fan cooling													
Weight/Mass [kg]	IP21/IP55	70	70												
	IP00			62	64	94	98	129	140	245	245	245	330	530	530

*1) Applicable standard motors are the case of Fuji Electric's 4-pole standard motors.

*2) The rated capacity indicates the case of 440V ratings.

*3) Output voltage cannot exceed the power supply voltage.

*4) Interphase voltage unbalance ratio [%] = (max. voltage [V] - min. voltage [V]) / 3-phase average voltage [V] x 67 (See IEC61800-3.) When unbalance ratio is between 2 and 3% please use optional AC reactor (ACR).

*5) Average braking torque obtained by use of a motor (Varies with the efficiency of the motor).

Dimensions

Power supply voltage	Applicable standard motor (kW)	Inverter model	Outside dimensions (mm)					Mounting dimensions (mm)					
			View	W	H	D	D1	D2	View	W1	W2	H1	H2
3-phase 400 V	0.75	FRN0.75AQ1□-4E	A	150	465	262	162	100	B	115	17	451	7
	1.5	FRN1.5AQ1□-4E											
	2.2	FRN2.2AQ1□-4E											
	3.7	FRN3.7AQ1□-4E											
	5.5	FRN5.5AQ1□-4E											
	7.5	FRN7.5AQ1□-4E											
	11	FRN11AQ1□-4E											
	15	FRN15AQ1□-4E											
	18.5	FRN18.5AQ1□-4E											
	22	FRN22AQ1□-4E											
	30	FRN30AQ1□-4E											
	37	FRN37AQ1□-4E											
	45	FRN45AQ1□-4E	C	265	736	284	184	127	D	180	42	716	12
	55	FRN55AQ1□-4E											
	75	FRN75AQ1□-4E											
	90	FRN90AQ1□-4E											
	110	FRN110AQ1S-4E											
	132	FRN132AQ1S-4E											
	160	FRN160AQ1S-4E											
	200	FRN200AQ1S-4E											
	220	FRN220AQ1S-4E											
280	FRN280AQ1S-4E												
315	FRN315AQ1S-4E	C	680	1400	440	260	186	D	50	1370	15		
355	FRN355AQ1S-4E												
400	FRN400AQ1S-4E												
500	FRN500AQ1S-4E												
630	FRN630AQ1S-4E												
710	FRN710AQ1S-4E												

□ Protective structure: M : IP21, L : IP55, S: IP00. Type of frame: up to 37 kW plastic enclosure and 45 kW and above metal enclosure.

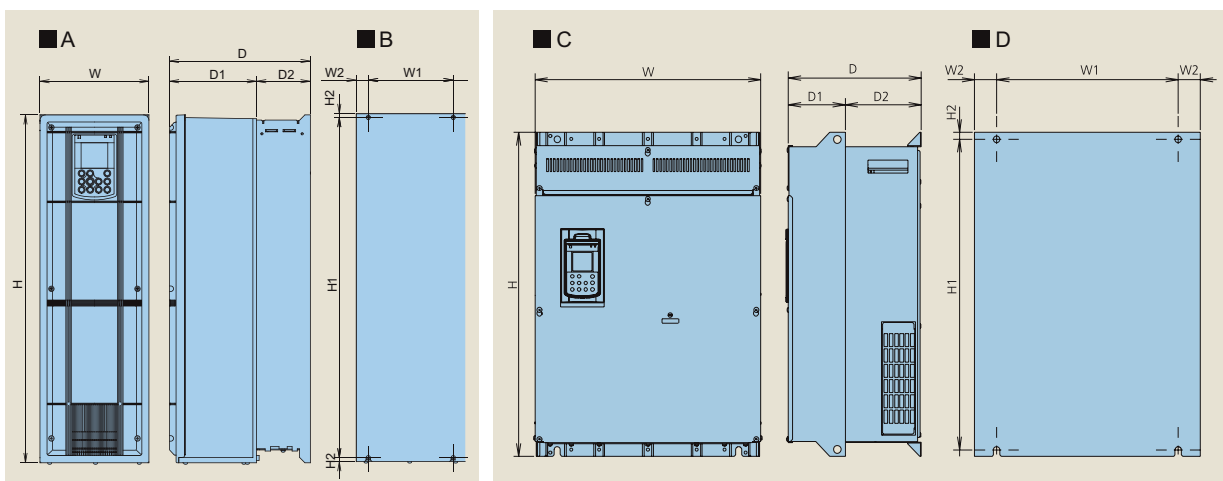
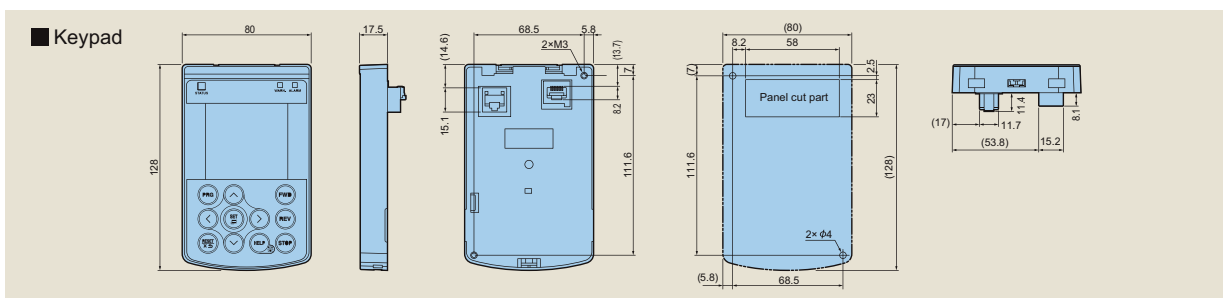

Wiring diagram

Basic configuration diagram

Factory shipped condition: with SOURCE mode input and enable input function

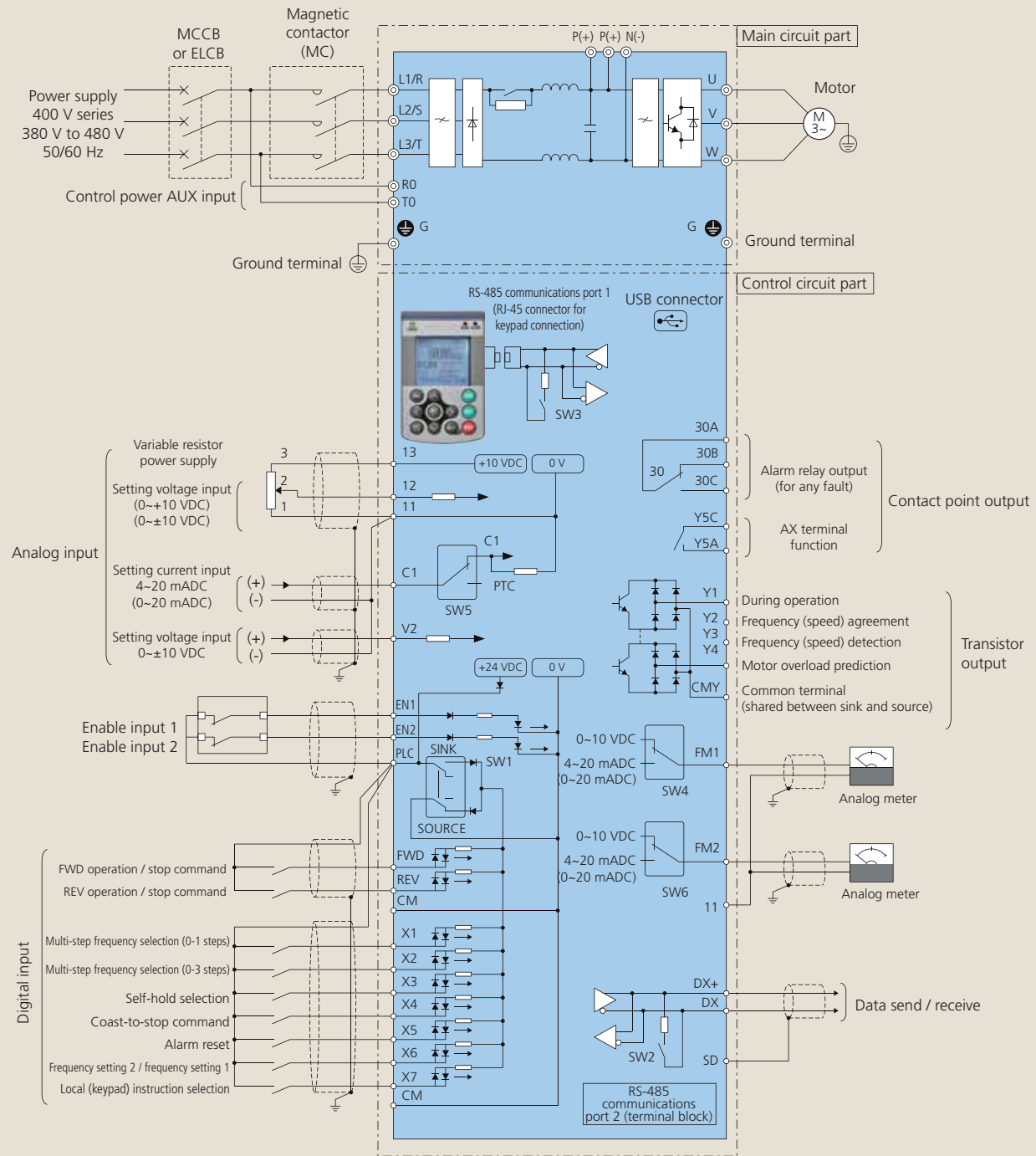

Options

Relay output interface card (OPC-RY)

This is an optional card that converts the transistor output at terminals Y1 to Y4 on the inverter body to relay output (1c). Each card has two relay outputs, and four relay outputs are available by installing two cards.

Relay output:	2 circuits built-in
Signal type:	1c
Contact point capacity:	AC 250 V; 0,3 A $\cos \varphi = 0.3$ DC 48 V; 0,5 A (resistance load)

Analog input interface card (OPC-AIO)

This card allows analog input and output to be used.

Analog input:	1 analog voltage input point (0 ~ ±10 V) 1 analog current input point (4 ~ 20 mA)
Analog output:	1 analog voltage output point (0 ~ ±10 V) 1 analog current output point (4 ~ 20 mA)

CC-Link communications card (OPC-CCL)

By connecting this card with the CC-Link master unit, the communications rate up to 10 Mbps can be supported and the transmission distance is covered up to 1200 m in total.

No. of connection units:	42 units
Communication method:	CC-Link Ver1.10 and Ver2.0
Communications rate:	156 kbps~

PROFIBUS DP communications card (OPC-PDP2)

This card enables operation instruction and frequency command to be set from the PROFIBUS DP master, allowing operation conditions to be monitored and all the function codes to be changed and checked.

Communications rate:	9,6 kbps ~12 Mbps
Transmission distance:	~1,200 m
Connection connector:	6-pole terminal block

LonWorks communications card (OPC-LNW)

This card allows peripheral equipment (including a master unit) that is connected via LonWorks to be connected with the inverter, enabling operation instruction and frequency command to be set from the master unit.

Extension cable for remote operation (CB-□S)

This cable is used in connection between the inverter body and the keypad.

Optional type	Length (m)
CB-5S	5
CB-3S	3
CB-1S	1

Relay output interface card (OPC-RY2)

This optional card allows relay outputs (1a) to be added. When used in cascaded control, this card can control the seven motors.

* By using the two relay outputs on the inverter body, max. 8 units and one unit (auxiliary pump) can be controlled.

Relay output:	7 circuits built-in
Signal type:	1a
Contact point capacity:	AC 250 V; 0,3 A $\cos \varphi = 0.3$ DC 48 V; 0,5 A (resistance load)

Analog current output interface card (OPC-AO)

This card allows two analog current output (4 to 20mA) points to be used. The card cannot be used together with OPC-AIO.

DeviceNet communications card (OPC-DEV)

This card enables operation instruction and frequency command to be set from the DeviceNet master, allowing operation conditions to be monitored and all the function codes to be changed and checked.

No. of connection nodes:	max. 64 units (including the master unit)
MAC ID:	0-63
Insulation:	500 V DC (photocoupler insulation)
Communications rate:	500 kbps / 250 kbps / 125 kbps
Network consumed power:	max. 80 mA, 24 VDC

CANopen communications card (OPC-COP)

This card enables operation instruction and frequency command to be set from the CANopen master (such as PC and PLC), allowing all the function codes to be set and checked.

No. of connection nodes:	127 units
Communication rate:	20 k, 50 k, 125 k, 250 k, 500 k, 800 k, 1 Mbps
Transmission distance:	~2,500 m

Ethernet communications card (OPC-ETH)

Mounting the communications card OPC-ETH on the FRENIC-AQUA enables the user to control the FRENIC-AQUA as a slave unit by configuring and monitoring run and frequency commands and accessing inverter's function codes from the Ethernet master.

Pt100 temperature sensor input card (OPC-PT)

This product is a 2-channels resistance temperature detectors input card which can be equipped to FRENIC-AQUA series. This interface card allows the resistance temperature detector (hereafter RTD) to be directly connected without converters to the inverter and convert a temperature values into a digital value. Applicable RTD are "JPt100", "Pt100", "Ni100", "Pt1000", and "Ni1000".

Battery (OPK-BP)

Used for the real time clock activated while the inverter power is off. The real time clock can be operated even when no power is supplied inverter at electric power interruption.

European Headquarters
Fuji Electric Europe GmbH
Goethering 58
63067 Offenbach/Main
Germany
Tel.: +49 69 669029 0
Fax: +49 69 669029 58
info.inverter@fujielectric-europe.com
www.fujielectric-europe.com

Spain
Fuji Electric Europe GmbH
Sucursal en España
C/ dels Paletes 8, Edifici B, Primera
Planta B, Parc Tecnològic del Vallès
08290 Cerdanyola (Barcelona)
Tel.: +34 93 5824333
Fax: +34 93 5824344
info.spain@fujielectric-europe.com
www.fujielectric-europe.com

Italy
Fuji Electric Europe GmbH
Filiale Italiana
Via Rizzotto 46
41126 Modena (MO)
Tel.: +39 059 4734266
Fax: +39 059 4734294
info.italy@fujielectric-europe.com
www.fujielectric-europe.com

Global Headquarters Japan
Fuji Electric Co., Ltd.
Gate City Ohsaki East Tower
11-2 Osaki 1-chome, Shinagawa-ku,
Tokio 141-0032 Japan
Tel.: +81 3 5435 7058
www.fujielectric.com

Switzerland
Fuji Electric Europe GmbH
Swiss Branch
Rietlistrasse 5
9403 Goldach
Tel.: +41 71 85829 49
Fax: +41 71 85829 40
info.swiss@fujielectric-europe.com
www.fujielectric-europe.com

France
Fuji Electric Europe GmbH
Succursale France
265 Rue Denis Papin
38090 Villefontaine
Tel.: +33 4 74 90 91 24
Fax: +33 4 74 90 91 75
info.france@fujielectric-europe.com
www.fujielectric-europe.com

United Kingdom
Fuji Electric Europe GmbH
UK Branch
Bedford i-Lab
Stannard Way, Priory Business Park
Bedford MK44 3RZ
Tel.: +44 1234 834 768
info.uk@fujielectric-europe.com
www.fujielectric-europe.com