

### Your Advantage

- Safety contact multiplication

### Features

- According to
  - Performance Level (PL) e and category 4 to EN ISO 13849-1: 2008
  - SIL Claimed Level (SIL CL) 3 to IEC/EN 62061
  - Safety Integrity Level (SIL) 3 to IEC/EN 61508 and IEC/EN 61511 when connected to a suitable safety module
- According to EN 50156-1 for furnaces
- Control with safety semiconductor outputs (light curtain, e-stop) possible
- Redundant and forcibly guided contacts
- Output: max.7 NO or 6 NO contacts / 1 NC contact, 1 NC contact for feedback circuit
- 1- or 2-channel
- Indication
- As option with pluggable terminal blocks for easy exchange of devices
  - with screw terminals
  - or with cage clamp terminals
- Width: 22.5 mm

### Product Description

If more safety circuits have to be switched, than a safety module provides, the extension module UG 6929 is used. It offers safe and reliable contact multiplication and re-enforcement for safety modules with monitoring of the feedback circuit. Safe semiconductor outputs can be extended by relay output contacts. The extension module has forcibly guided contacts and can be delivered with different contact arrangements.

### Approvals and Markings



### Block Diagrams

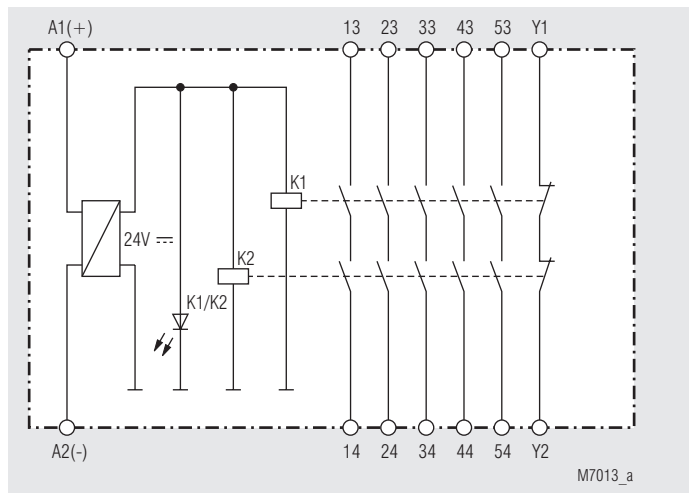

UG 6929.60

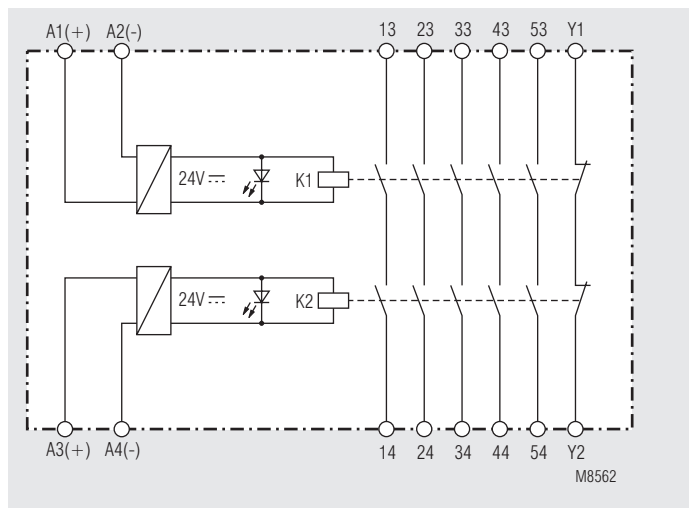

UG 6929.60/100

### Application

For multiply the number of safety output contacts of safety modules and gate monitors.

### Indicators

- UG 6929**  
green LED K1/K2: on, when relay K1 and K2 energized
- UG 6929/100**  
green LED K1: on, when relay K1 energized  
green LED K2: on, when relay K2 energized

### Notes

The extension module UG 6929 must only be used together with a safety unit e.g. (UG 6970) that monitors the feedback circuit Y1/Y2 to achieve (SIL CL) 3 acc. to IEC/EN 62061, SIL 3 to IEC/EN 61508, Performance Level (PL) e and category 4 to EN ISO 13849-1: 2008.

### Connection Terminals

Terminal designation	Signal designation
A1 (+), A3 (+)	+ / L
A2, A4	- / N
13, 14, 23, 24, 33, 34, 43, 44, 53, 54, 63, 64, 73, 74	Forcibly guided NO contacts for release circuit
31, 32, 51, 52, 71, 72	Forcibly guided indicator output
Y1, Y2	Forcibly guided feedback circuit

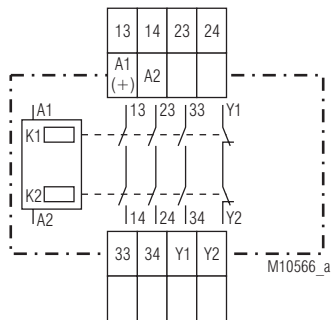

UG6929.03

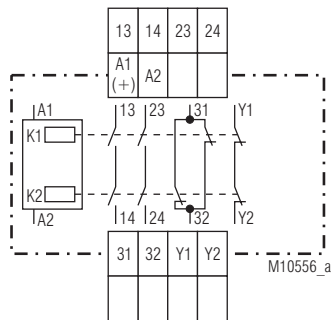

UG6929.22

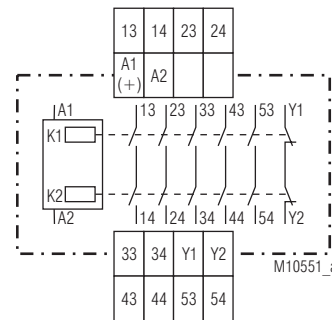

UG6929.60

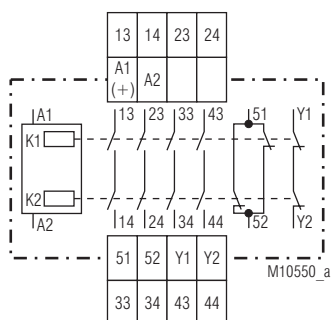

UG6929.54

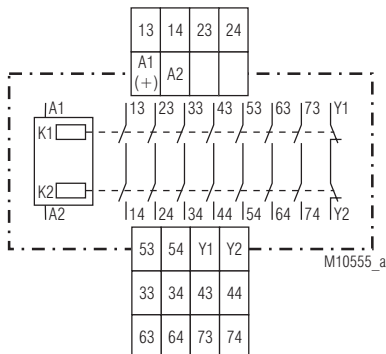

UG6929.62 (on request)

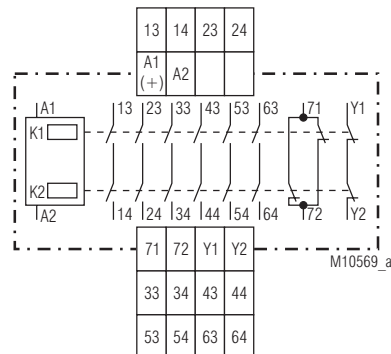

UG6929.61 (on request)

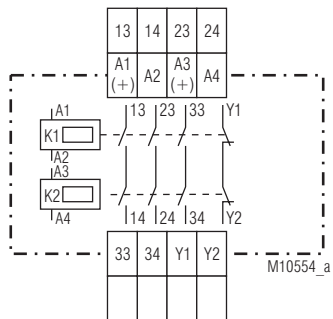

UG6929.03/100

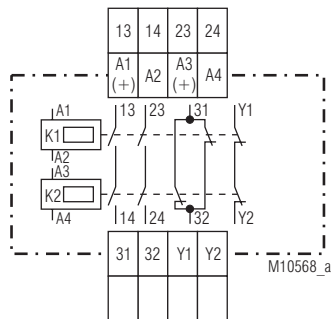

UG6929.22/100

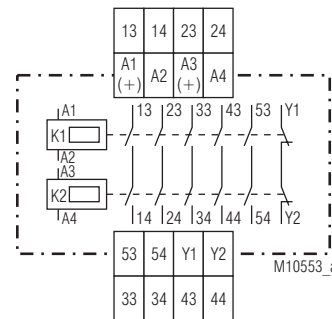

UG6929.60/100

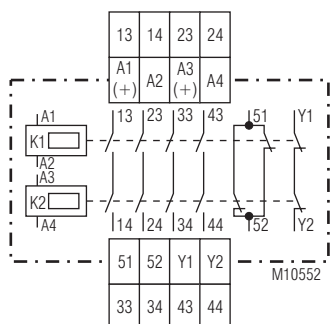

UG6929.54/100

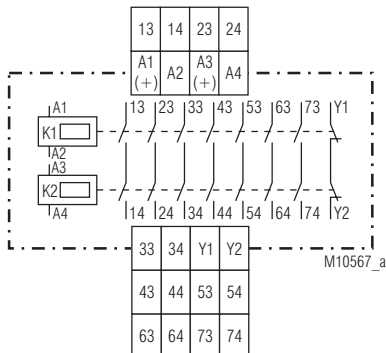

UG6929.62/100 (on request)

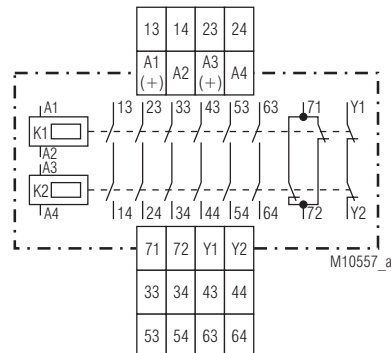

UG6929.61/100 (on request)

Technical Data	
<b>Input</b>	
<b>Nominal voltage <math>U_N</math>:</b>	AC/DC 24 V AC 120 V, AC 230 V
<b>Voltage range:</b>	0.8 ... 1.1 $U_N$
<b>Nominal consumption</b>	
AC/DC 24 V:	typ. 1.8 VA
AC120 V, AC 230 V:	typ. 3,4 VA
<b>Nominal frequency:</b>	50/60 Hz
<b>Output</b>	
<b>Contacts</b>	
UG 6929.03, UG 6929.03/100:	3 NO contacts, 1 NC contact for feedback circuit
UG 6929.22, UG 6929.22/100:	2 NO contacts, 2 NC contacts for feedback and indicator circuit
UG 6929.60, UG 6929.60/100:	5 NO contacts, 1 NC contact for feedback circuit
UG 6929.54, UG 6929.54/100:	4 NO contacts, 2 NC contacts for feedback and indicator circuit
on request	
UG 6929.62, UG 6929.62/100:	7 NO contacts, 1 NC contact for feedback circuit
UG 6929.61, UG 6929.61/100:	6 NO contacts, 2 NC contacts for feedback and indicator circuit
<b>Operate time:</b>	max. 20 ms
<b>Release time:</b>	max. 35 ms
<b>Nominal output voltage:</b>	AC 250 V DC: see arc limit curve under resistive load) Y1/Y2: max. DC 30 V
<b>Thermal current <math>I_{th}</math>:</b>	max. 8 A (see quadratic total current limit curve)
<b>Switching capacity</b>	
to AC 15	
NO contacts:	3 A / AC 230 V IEC/EN 60 947-5-1
NC contacts:	2 A / AC 230 V IEC/EN 60 947-5-1
to DC 13	
NO contacts:	2 A / DC 24 V IEC/EN 60 947-5-1
NC contacts:	2 A / DC 24 V IEC/EN 60 947-5-1
to DC 13	
NO contacts:	4 A / 24 V at 0.1 Hz IEC/EN 60 947-5-1
NC contacts:	4 A / 24 V at 0.1 Hz IEC/EN 60 947-5-1
<b>Electrical life</b>	
at 5 A, AC 230 V $\cos \varphi = 1$ :	> 2,2 x 10 <sup>5</sup> switching cycles
<b>Perm. switching frequency:</b>	1200 switching cycles / h
<b>Short circuit strength</b>	
max. fuse rating:	6 A gL IEC/EN 60 947-5-1
<b>Mechanical life:</b>	
	20 x 10 <sup>6</sup> switching cycles
<b>General Data</b>	
<b>Nominal operating mode:</b>	continuous operation
<b>Temperature range</b>	
Operation:	- 15 ... + 55 °C
Storage:	- 25 ... + 85 °C
<b>Altitude:</b>	< 2.000 m
<b>Clearance and creepage distance</b>	
rated impulse voltage / pollution degree:	4 kV / 2 IEC 60 664-1
<b>EMC</b>	
Electrostatic discharge (ESD):	8 kV (air) IEC/EN 61 000-4-2
HF irradiation:	10 V / m IEC/EN 61 000-4-3
Fast transients:	2 kV IEC/EN 61 000-4-4
Surge voltage between wires for power supply:	1 kV IEC/EN 61 000-4-5
between wire and ground:	2 kV IEC/EN 61 000-4-5
HF-wire guided:	10 V EN 61 000-4-6
<b>Interference suppression:</b>	Limit value class B EN 55 011
<b>Degree of protection</b>	
Housing:	IP 40 IEC/EN 60 529
Terminals:	IP 20 IEC/EN 60 529
<b>Housing:</b>	
	thermoplastic with VO behaviour according to UL subj. 94
<b>Vibration resistance:</b>	Amplitude 0,35 mm Frequency 10 ... 55 Hz, IEC/EN 60 068-2-6

Technical Data	
<b>Climate resistance:</b>	15 / 055 / 04 IEC/EN 60 068-1
<b>Terminal designation:</b>	EN 50 005
<b>Wire connection:</b>	DIN 46 228-1/-2/-3/-4
<b>Terminal block with screw terminal</b>	
Cross section:	1 x 0.25 ... 2.5 mm <sup>2</sup> solid oder stranded ferruled (isolated) or 2 x 0.25 ... 1.0 mm <sup>2</sup> solid or stranded ferruled (isolated)
Insulation of wires or sleeve length:	7 mm
<b>Terminal block with cage clamp terminals</b>	
<b>PC</b>	
Cross section:	1 x 0.25 ... 2.5 mm <sup>2</sup> solid or stranded ferruled (isolated)
Insulation of wires or sleeve length:	10 mm
<b>PT</b>	
Cross section:	1 x 0.25 ... 1.5 mm <sup>2</sup> solid or stranded ferruled (isolated)
Insulation of wires or sleeve length:	8 mm
<b>Wire fixing:</b>	captive slotted screw or cage clamp terminals
<b>Mounting:</b>	DIN rail IEC/EN 60 715
<b>Weight:</b>	approx. 210 g
<b>Dimensions</b>	
<b>Width x height x depth:</b>	
UG 6929 PS:	22.5 x 110 x 120.3 mm
UG 6929 PC, PT:	22.5 x 120 x 120.3 mm

#### Safety Related Data

#### Values according to EN ISO 13849-1:

Category:	4	
PL:	e	
MTTF <sub>d</sub> :	144.3	a
DC <sub>avg</sub> :	99.0	%
d <sub>op</sub> :	365	d/a (days/year)
h <sub>op</sub> :	24	h/d (hours/day)
t <sub>cycle</sub> :	3600	s/cycle
	≥ 1	/h (hour)

#### Values according to IEC/EN 62061 / IEC/EN 61508 / IEC/EN 61511:

SIL CL:	3	IEC/EN 62061
SIL:	3	IEC/EN 61508 / IEC/EN 61511
HFT <sup>1)</sup> :	1	
DC <sub>avg</sub> :	99,0	%
SFF:	99,7	%
PFH <sub>D</sub> :	3.59E-10	h <sup>-1</sup>
PFD:	3.02E-05	
T <sub>1</sub> :	20	a

<sup>1)</sup> HFT = Hardware failure tolerance



The values stated above are valid for the standard type. Safety data for other variants are available on request.

The safety relevant data of the complete system has to be determined by the manufacturer of the system.

## UL-Data

The safety functions were not evaluated by UL. Listing is accomplished according to requirements of Standard UL 508, "general use applications"

**Contact version:** .03, .22, .54, .60  
**Switching capacity:** Pilot duty B300, Q300  
 5A 250Vac Resistive or G.P.  
 5A 24Vdc Resistive

**Wire connection:** 60°C / 75°C copper conductors only  
**PS-terminal:** AWG 28 - 12 Sol/Str Torque 0.5 Nm  
**PC-terminal:** AWG 24 - 12 Sol/Str  
**PT-terminal:** AWG 24 - 16 Sol/str



Technical data that is not stated in the UL-Data, can be found in the technical data section.

## Standard Type

UG 6929.60PS/61 AC/DC24V  
 Article number: 0065304  
 • Output: 5 NO contacts,  
 1 NC contact for feedback circuit  
 • Nominal voltage: AC/DC 24 V  
 • Width: 22.5 mm

## Variant

UG 6929.\_.\_/100: for 2-channel with 2 LEDs,

## Ordering example for variant

UG 6929 . \_ . \_ / 100 / 61 AD/DC 24 V

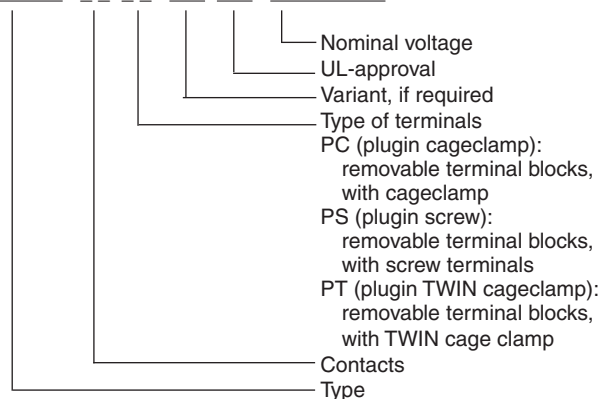

## Options with Pluggable Terminal Blocks

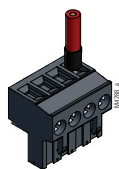

Screw terminal  
 (PS/plugin screw)

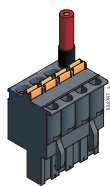

Cage clamp terminal  
 (PC/plugin cage clamp)



TWIN Cage clamp terminal  
 (PT/plugin TWIN cage clamp)

## Characteristics

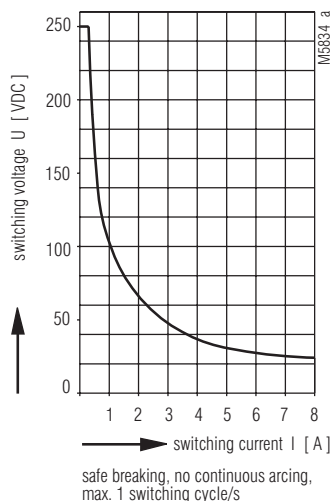

## Arc limit curve under resistive load

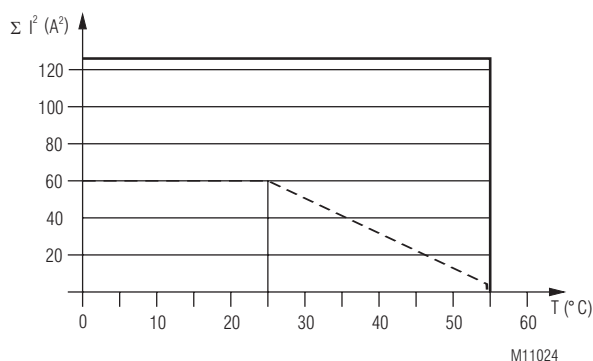

— AC 230V device mounted on distance with air circulation.  
 max. current at 55°C over  
 5 contact path =  $5A \triangleq 5 \times 5^2 A^2 = 125 A^2$

- - - AC 230V device mounted without distance heated by  
 devices with same load,  
 max current at 55°C over  
 5 contact path =  $1A \triangleq 5 \times 1^2 A^2 = 5 A^2$

Quadratic total current

$$\Sigma I_{th}^2 = I_{th1}^2 + I_{th2}^2 + I_{th3}^2 + I_{th4}^2 + I_{th5}^2$$

$I_{th1}, I_{th2}, I_{th3}, I_{th4}, I_{th5}$ : current in contact paths

## Quadratic total current limit curve AC 230 V

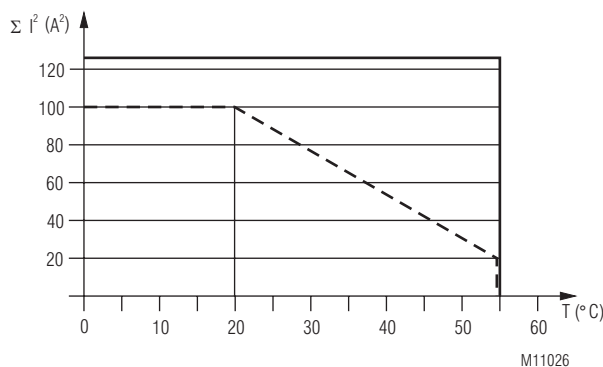

— AC / DC 24V device mounted on distance with air circulation.  
 max. current at 55°C over  
 5 contact path =  $5A \triangleq 5 \times 5^2 A^2 = 125 A^2$

- - - AC / DC 24V device mounted without distance heated by  
 devices with same load,  
 max current at 55°C over  
 5 contact path =  $2A \triangleq 5 \times 2^2 A^2 = 20 A^2$

Quadratic total current

$$\Sigma I_{th}^2 = I_{th1}^2 + I_{th2}^2 + I_{th3}^2 + I_{th4}^2 + I_{th5}^2$$

$I_{th1}, I_{th2}, I_{th3}, I_{th4}, I_{th5}$ : current in contact paths

## Quadratic total current limit curve AC/DC 24 V

## Application Examples

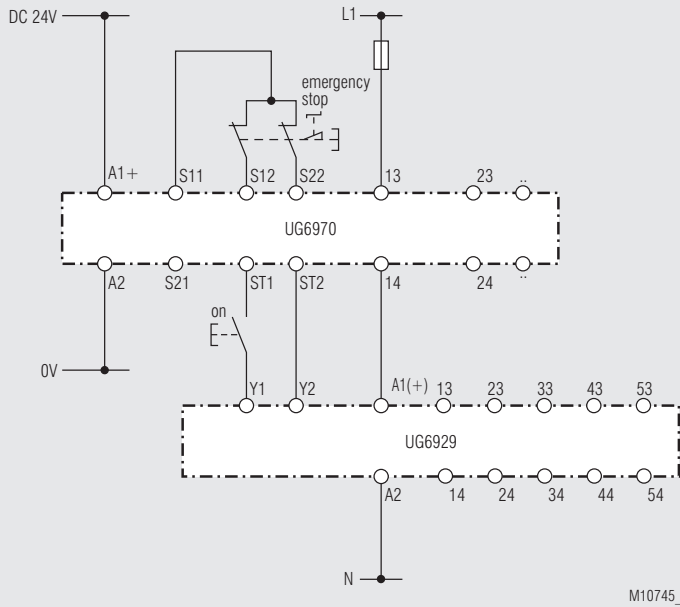

UG 6929; suited up to SIL3, Performance Level e, Cat. 4

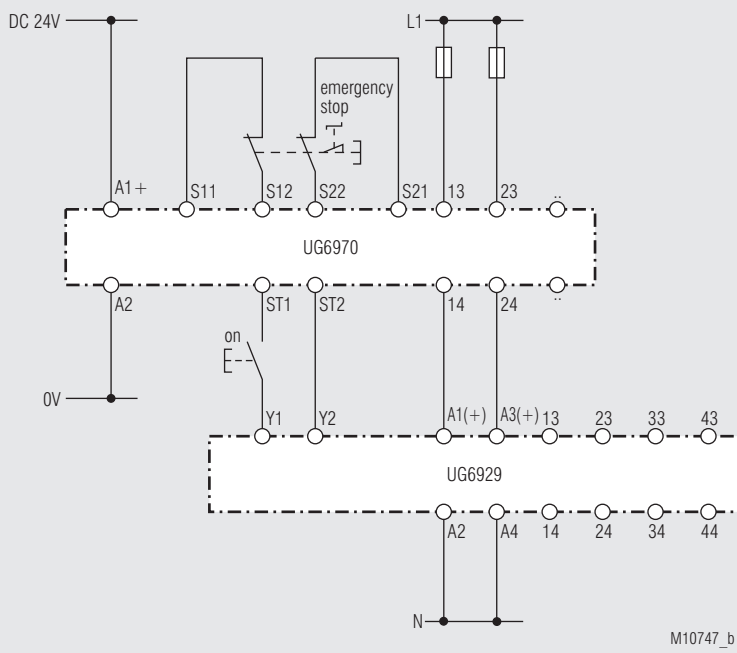

Contact extensions with UG6929/100; suited up to SIL3, Performance Level e, Cat. 4

