

MINISTART Softstart- / Softstop Device GI 9014



GI 9014

GI 9014 with DeviceNet-module

Function Diagram

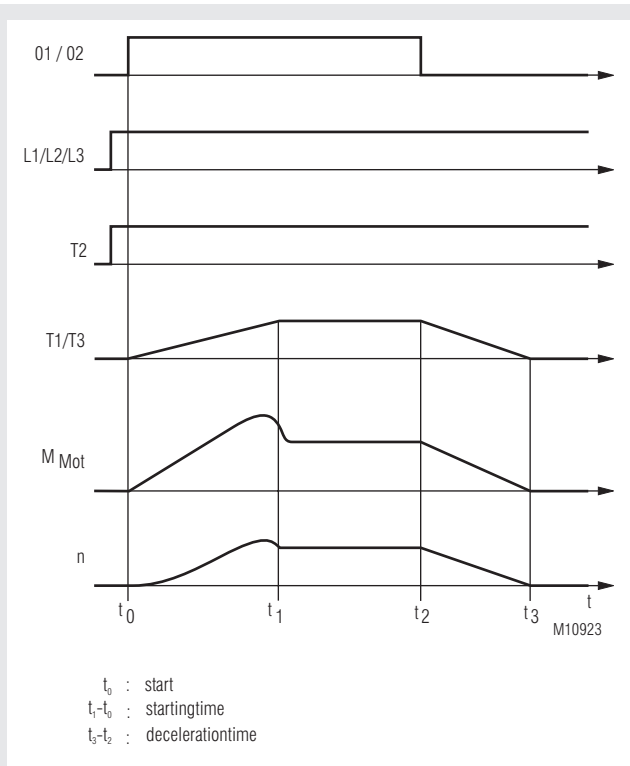

Block Diagram

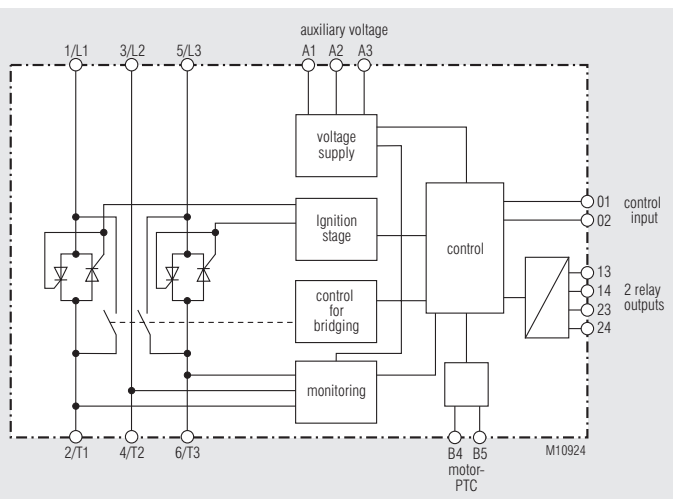

Your Advantages

- Protection of the drive unit
- Space and cost saving because of integrated motor protection:
 - motor overload, phase failure and exceed acceleration time
- Integrated bridging contactor
- Limiting of starting current prevents against mains and equipment overload
- Productivity by shortened starting times on heavy duty starting and high permissible switching frequency
- Individual configuration for every application
- Easy operation
- Comprehensive diagnostic via LED-flashing codes possible

Features

- 2-phase softstarter for asynchronous motors up to 110 kW (400 V)
- Integrated current control time
- Integrated motor protector
- Integrated bridging contactor
- Volt free control input for softstart / -stop
- Connection for motor thermistor
- With two monitoring outputs, one is programmable
- DIN rail mounting with devices up to 30 kW
- Communication interfaces for Profibus, DeviceNet, Modbus and pump controls (optional)
- Start and stop via separate push buttons or control switch
- Motor voltage range 3 AC 200 ... 440V or 3 AC 200 ... 575V

Adjustable functions:

- Starting time monitoring
- Nominal motor current
- Current ramp
- Current limit
- Softstop - ramp time
- Motor protection class
- Phase sequence
- Programmable relay output for indicators

Approval and Marking



Application

- Escalator
- Pumps
- Fans and ventilation systems
- Conveyor systems and elevators
- Compressors
- Mills, crushers, presses
- ... and for all applications with ambitious start-up and deceleration

Indication

LED "On": Indicate the device state
 LED "Bypass": Indicate the motor state
 flashes with same frequency at error
 Failure codes see in operating manual GI 9014

Technical Data

Nominal voltage: 3 AC 200 ... 440 V (+10 % / -15 %)
 3 AC 200 ... 575 V (+10 % / -15 %)

Nominal frequency: (at start): 45 ... 66 Hz

Rated current I_N (A):	18	34	42	48	60	75	85	100	140	170	200
Motor power at 400 V (kW):	7,5	15	18,5	22	30	37	45	55	75	90	110
Stromrampe:	2 s, 5 s, 15 s with 150 %; 200 % and 250 % I_N										
Stromgrenze:	250%, 275%, 300%, 325%, 350%, 375%, 400%, 425%, 450% I_N										
Motor protection class:	adjustable										
Deceleration time:	2 s ... 20 s										
operating frequency 4 x I_e and 6 s:	AC 53b 10/h					AC 53b 6/h					
Weight (kg):	2.4			4.3				6.8			

Auxiliary voltage (A1, A2, A3)

optionally: AC 380 to 440 V (+ 10% / - 15%)
 and AC 110 to 240V (+ 10% / - 15%)
or
 AC/DC 24 V (\pm 20%)

Current consumption

(at operation): < 100 mA

Current consumption

(at starting)

at auxiliary voltage AC 110...440V: 10 A for 10 ms

at auxiliary voltage AC/DC 24 V: 2 A for 10 ms

Inputs

Start (terminal 01)

NO contact:

150 k Ω at AC 300 V and
 5.6 k Ω at DC 24 V

Stop (terminal 02)

NC contact:

150 k Ω at AC 300 V and
 5.6 k Ω at DC 24 V

Outputs

Main contactor (terminals 13, 14)

NO contact:

6 A, DC 30 V resistive /
 2 A, AC 400 V, AC11

programmable relay

(terminal 23, 24)

NO contact:

6 A, DC 30 V resistive /
 2 A, AC 400 V, AC11

General Data

Degree of protection

at 7.5 ... 55 kW: IP 20 IEC/EN 60 529

at 75 ... 110 kW: IP 00 IEC/EN 60 529

IIP 20 with additional finger guard kit
 (see accessories)

Temperature range

operation:

- 10 °C to + 60 °C
 (over +40 °C see derating at Commissioning
 Instructions)

storage temperature:

- 25 ... + 60°C
 (to +70 °C for max . 24 h)

Humid: 5% ... 95% relative humid

Rated voltage of insulation: 600 V

Pollution degree: 3

Vibration resistance: Test according to IEC 60068

4 Hz ... 13.2 Hz \pm 1 mm Amplitude

13.2 Hz ... 200 Hz: \pm 0.7 g

EMC

Electrostatic discharge (ESD): 4 kV (contacts) IEC/EN 61 000-4-2

8 kV (air) IEC/EN 61 000-4-2

Conducted radio frequency

emission: 0.15 MHz to 1000 MHz: 140 dB (μ V)

Technical Data

Surge voltage

between

wires for power supply: 1 kV IEC/EN 61 000-4-5

between wire and ground: 2 kV IEC/EN 61 000-4-5

Fast transients: 5/50 μ s

Voltage dip and

short time interruption: 100 ms (at 40 % nominal voltage)

Harmonics and distortion: IEC 61000-2-4 (class 3), IEC/EN61800-3

Short circuit

Short circuit current

7.5 ... 37 kW: 5 kA

55 ... 110 kW: 10 kA

Heat dissipation:

during start: 3 W/A

during operation: 10 W

Dimensions

Width x height x depth

7.5 / 15 / 18.5 / 22 / 30 kW: 98 x 203 x 165mm

37 / 45 / 55 kW: 145 x 215 x 193 mm

75 / 90 / 110 kW: 202 x 240 x 214 mm

Standard type

GI 9014 3 AC 200 ... 440 V 45 ... 66 Hz 7.5 kW

• Article number: 0062420

• Nominal voltage: 3 AC 200 ... 440 V

• Auxiliary voltage: DC 24 V

• Nominal motor power: 7.5 kW

• Width: 98 mm

Ordering Example

GI 9014 3 AC 200 ... 440 V 45/66 Hz 7.5 kW 3 AC 380 bis 440 V

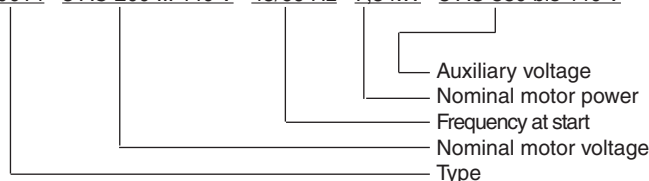

Accessories

- GW 5310: Remote control
- GW 5311: Interface for remote control
- GW 5312: DeviceNet-Module
- GW 5313: Modbus-Module
- GW 5314: Profibus-Module
- GW 5316: Finger guard kit and touch protection

Connection Examples

