

POWERSWITCH Semiconductor Contactor BF 9250/_ _8

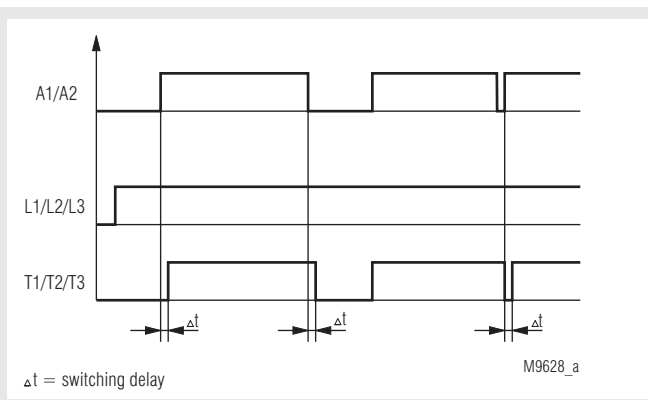

- According to IEC/EN 60 947-4-2, IEC/EN 60 947-4-3
- 1-, 2- and 3-pole versions
- Load current up to 50 A at $T_U = 40^\circ \text{C}$
- For AC load up to 530 V
- Switching at zero crossing, optionally immediate switching
- Protected by varistors
- Mounting on DIN-rail
- as option with high I^2t of the semiconductor for high switching current (variant /1_8)
- Widths: 22.5 mm, 45 mm and 90 mm

Function Diagram



Approvals and Markings



Applications

Fast and noiseless switching of:

- heating elements
- motors
- valves
- lighting

Block Diagram

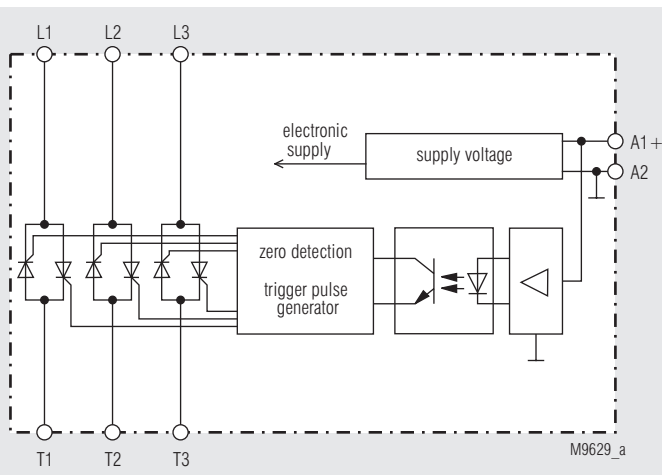

Indication

LED green: on, when voltage on A1/A2

Circuit Diagrams

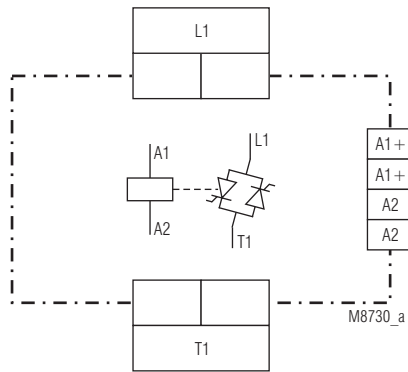

BF 9250.91/008 (1-pole)

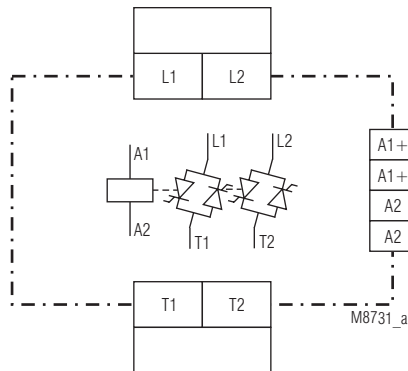

BF 9250.92/008 (2-pole)

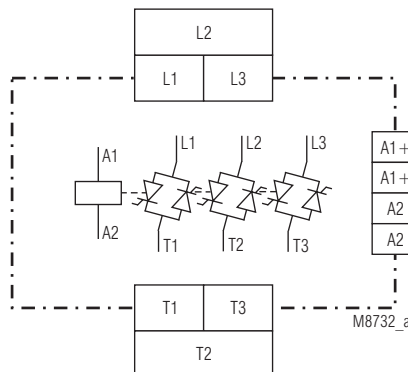

BF 9250.93/008 (3-pole)

Technical Data

Input:

Control voltage A1/A2:	DC 24 V
Control voltage range:	
1-pole:	DC 4 ... 32 V
2-pole:	DC 7 ... 32 V
3-pole:	DC 9 ... 32 V
Start up delay [ms]:	≤ 1 + 1/2 period *)
Release delay [ms]:	≤ 1 + 1/2 period *)
	*) for variant with immediate switching only 1 periode for on and off delay

Output

Load output T1, T2, T3

Load currents at 100 % duty cycle:

BF 9250/008	Ambient temperature	Width		
		22.5 mm	45 mm	90 mm
1-pole	25°C	13 A	30 A	55 A
	40°C	10 A	25 A	50 A
2-pole	25°C	7 A	17.5 A	28 A
	40°C	6.5 A	15 A	25 A
3-pole	25°C	6 A	14 A	20 A
	40°C	5 A	10 A	15 A

Current reduction over 40°C

BF 9250/008	Device without heat sink	Device with small heat sink	Device with large heat sink
1-pole	0.2 A / °C	0.4 A / °C	0.6 A / °C
2-pole	0.2 A / °C	0.3 A / °C	0.4 A / °C
3-pole	0.2 A / °C	0.2 A / °C	0.3 A / °C

Min. load current:	AC 40 mA
Load voltage L1, L2, L3:	AC 230 V, AC 480 V
Load voltage range::	24 ... 264 V, AC 24 ... 530 V
Frequency range:	50 / 60 Hz
Leakage current in off state:	approx. 1.0 mA
Peak reverse voltage:	± 1 200 Vp
Short circuit current at t=10 ms	
BF 9250.91, BF 9250.92:	600 A
BF 9250.93:	400 A
Power dissipation:	P = 1.2 [V] x I eff. [A] / k [W] with k as formfactor and k = 1.11 for sinusoidal current

Semiconductor fuse

	I _N	Load limit integral of the semiconductor*)	Semiconductor fuse		
			Type	Art.-No.	Brand
1-pole devices	10 A	1800 A²s	fuse 10 x 38 NH-00	6003434.16	SIBA
	25 A			6003434.30	
	50 A			2020920.63	
2-pole devices	2 x 6.5 A	1800 A²s	fuse 10 x 38	6003434.10	SIBA
	2 x 15 A			6003434.20	
	2 x 25 A			6003434.30	
3-pole devices	3 x 5 A	800 A²s	fuse 10 x 38	6003434.8	SIBA
	3 x 10 A			6003434.16	
	3 x 15 A			6003434.20	

*) up to 18000 A²s: on request

Varistor voltage: AC 510 V

Technical Data

General Data

Mounting position:	cooling ribs vertically
Operating mode:	Continuous operation
Temperature range:	0 ... 40°C
max. temperature:	60°C (with current derating factor)
	see table
Storage temperature:	- 20 ... + 80°C

Clearance and creepage distances

rated impulse voltage / pollution degree	4 kV / 3	IEC 60 664-1
EMC	IEC/EN 61 000-6-4, IEC/EN 61 000-6-1	
Electrostatic discharge:	8 kVair / 6 kV contact	IEC/EN 61 000-4-2
HF-irradiation:	10 V / m	IEC/EN 61 000-4-3
Fast transients:	2 kV	IEC/EN 61 000-4-4

Surge voltages between		
wires for power supply:	1 kV	IEC/EN 61 000-4-5
between wire and ground:	2 kV	IEC/EN 61 000-4-5
HF-wire guided:	10 V	IEC/EN 61 000-4-6
Interference suppression:	Limit value class A	IEC/EN 60 947-4-3
	A higher suppression class can be reached by connecting capacitors of 0.47 µF / 600 V AC across the phases	

or across phase and neutral.

Insulation voltages

Input to Output:	2.5 kV
Input to semiconductor monitoring output (NC contact)	2.0 kV
Input to heat sink:	2.5 kV
Output to Output:	2.5 kV
Output to heat sink:	2.5 kV

Degree of protection

Housing:	IP 40	IEC/EN 60 529
Terminals:	IP 20	IEC/EN 60 529

Vibration resistance:

Amplitude 0.35 mm	
frequency 10 ... 55 Hz	IEC/EN 60 068-2-6
0 / 060 / 04	IEC/EN 60 068-1

Climate resistance:

Terminal designation:

Wire connection

Load terminals:	DIN 46 228-1/-2/-3/-4	
	1 x 10 mm ² solid	
	1 x 6 mm ² stranded ferruled	
Control terminals:	1 x 0.75 mm ² stranded ferruled (isolated)	
	DIN 46 228-1/-2/-3/-4	
	1 x 1.5 mm ² stranded ferruled	
	DIN 46 228-1/-2/-3	

Wire fixing

Load terminals:	Terminal screws M 4	
	Box terminal with wire protection	
Control terminals:	cage clamp terminals	
Mounting:	DIN rail	IEC/EN 60 715

Weight

Width 22.5 mm:	350 g
Width 45 mm:	580 g
Width 90 mm:	1050 g

Dimensions

Width x height x depth:

Dependent of contacts and load current (see table load current):	22.5 x 85 x 120 mm
	45 x 85 x 120 mm
	90 x 85 x 120 mm

Standard Types

BF 9250.91/008 DC 24 V AC 480 V 50/60 Hz 10 A

Article number: 0056823

- 1-pole
- Control voltage range: DC 4 ... 32 V
- Load voltage range: AC 24 ... 530 V
- Load voltage: 10 A (bei T_U = 40° C)
- with indicator output
- Width: 22.5 mm

Ordering Example

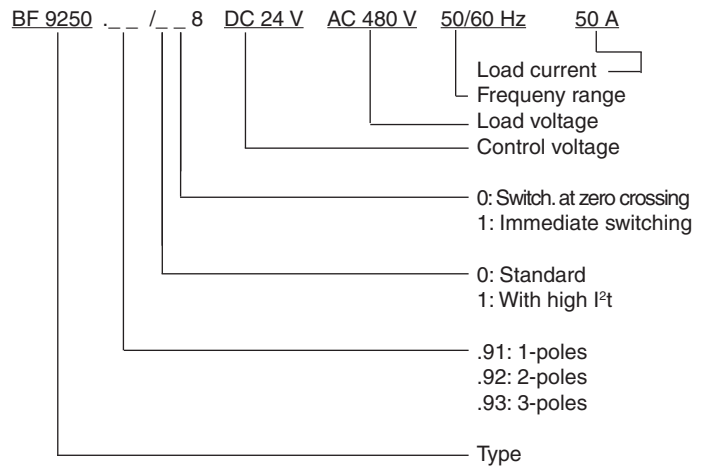

Installation

Recommended distance:

upper / lower side to cable duct: 20 mm

distance on left and right: 10 mm; with max. load current and 100 % duty cycle

Application Examples

single phase system

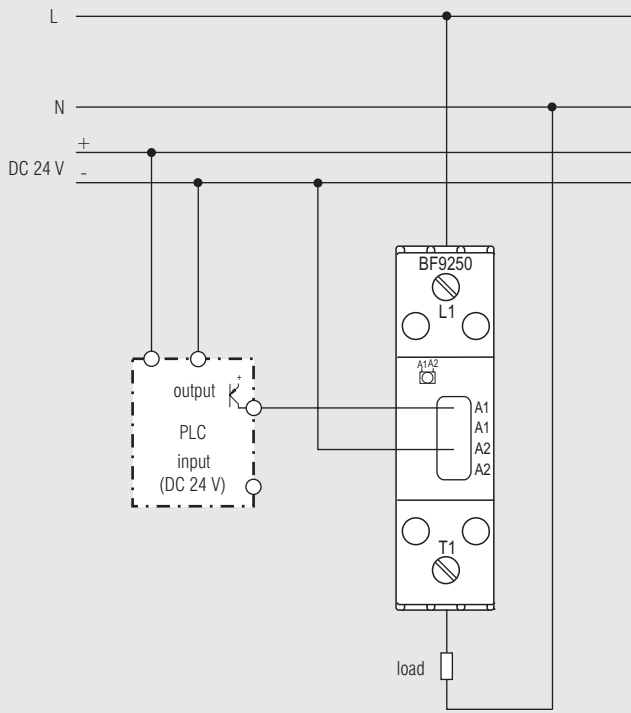

M9630

Single phase load switched by 1-pole semiconductor contactor controlled from PLC or Temperature controller output.

Width mm	22.5	45	90
I_L / phase	10 A	25 A	50 A

3-phase system, 2 phases controlled

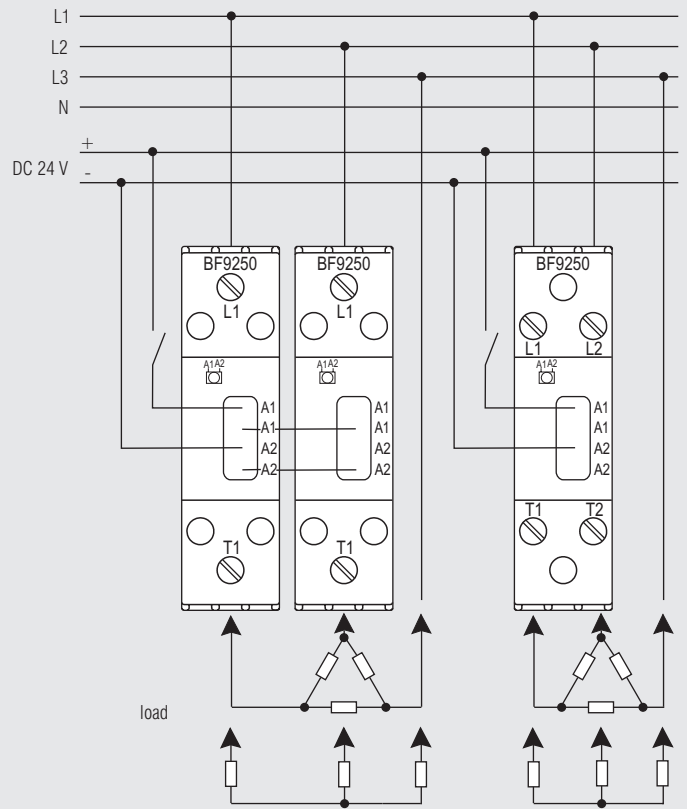

M9631

3-phase load, switched by 2 single-pole semiconductor contactors (left side) or by 1 2-pole semiconductor contactor (right side)

22.5	45	90
10 A	25 A	50 A

22.5	45	90
6.5 A	15 A	25 A

Application Example

3-phase system, 3-phases controlled

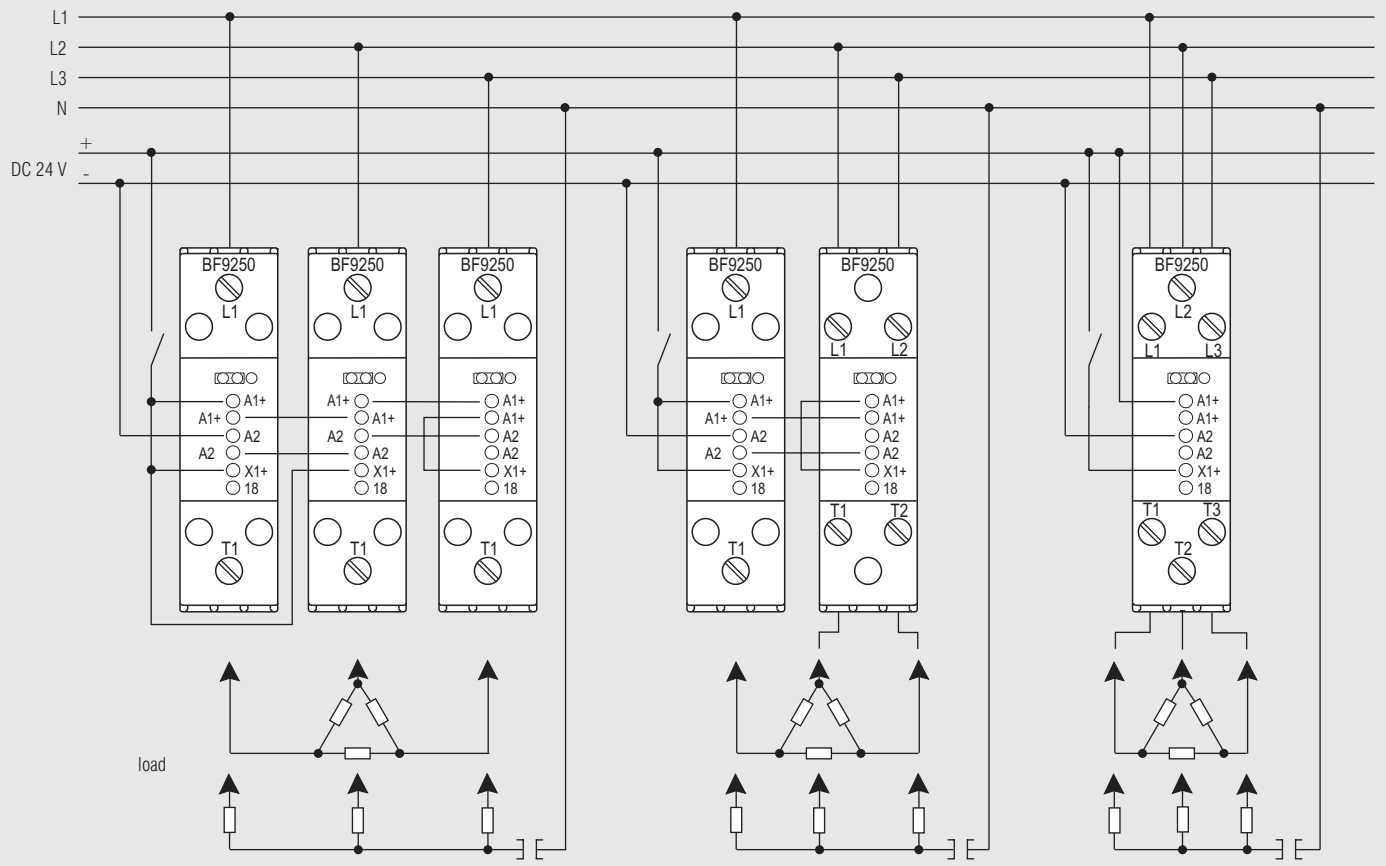

M9633

3-phase load switched by 3 single-pole semiconductor contactors

3-phase load switched by 1 single-pole and 1 2-pole semiconductor contactor

3-phase load switched by 1 3-pole semiconductor contactor

Width mm	22.5	45	90
I_L / phase	10 A	25 A	50 A

22.5	45	90
6.5 A	15 A	25 A

22.5	45	90
5 A	10 A	15 A

